

Programmable Controller

**MELSEC iQ-R**  
series

## MELSEC iQ-R I/O Module User's Manual

---

-RX10	-RY10R2
-RX10-TS	-RY10R2-TS
-RX28	-RY18R2A
-RX40C7	-RY20S6
-RX40C7-TS	-RY40NT5P
-RX41C4	-RY40NT5P-TS
-RX41C4-TS	-RY41NT2P
-RX42C4	-RY41NT2P-TS
-RX40PC6H	-RY41NT2H
-RX40NC6H	-RY42NT2P
-RX41C6HS	-RY40PT5P
-RX61C6HS	-RY40PT5P-TS
-RX70C4	-RY41PT1P
-RX71C4	-RY41PT1P-TS
-RX72C4	-RY41PT2H
	-RY42PT1P
	-RH42C4NT2P
	-RG60



# SAFETY PRECAUTIONS



---

(Read these precautions before using this product.)

Before using this product, please read this manual and the relevant manuals carefully and pay full attention to safety to handle the product correctly.

The precautions given in this manual are concerned with this product only. For the safety precautions of the programmable controller system, refer to the MELSEC iQ-R Module Configuration Manual.

In this manual, the safety precautions are classified into two levels: "⚠ WARNING" and "⚠ CAUTION".

 <b>WARNING</b>	Indicates that incorrect handling may cause hazardous conditions, resulting in death or severe injury.
 <b>CAUTION</b>	Indicates that incorrect handling may cause hazardous conditions, resulting in minor or moderate injury or property damage.

Under some circumstances, failure to observe the precautions given under "⚠ CAUTION" may lead to serious consequences.

Observe the precautions of both levels because they are important for personal and system safety.

Make sure that the end users read this manual and then keep the manual in a safe place for future reference.

## [Design Precautions]

---

### **WARNING**

---

- Configure safety circuits external to the programmable controller to ensure that the entire system operates safely even when a fault occurs in the external power supply or the programmable controller. Incorrect output or malfunction due to a communication failure may result in an accident.
    - (1) Emergency stop circuits, protection circuits, and protective interlock circuits for conflicting operations (such as forward/reverse rotations or upper/lower limit positioning) must be configured external to the programmable controller.
    - (2) When the programmable controller detects an abnormal condition, it stops the operation and all outputs are:
      - Turned off if the overcurrent or overvoltage protection of the power supply module is activated.
      - Held or turned off according to the parameter setting if the self-diagnostic function of the CPU module detects an error such as a watchdog timer error.
    - (3) All outputs may be turned on if an error occurs in a part, such as an I/O control part, where the CPU module cannot detect any error. To ensure safety operation in such a case, provide a safety mechanism or a fail-safe circuit external to the programmable controller. For a fail-safe circuit example, refer to "General Safety Requirements" in the MELSEC iQ-R Module Configuration Manual.
    - (4) Outputs may remain on or off due to a failure of a component such as a relay and transistor in an output circuit. Configure an external circuit for monitoring output signals that could cause a serious accident.
  - In an output circuit, when a load current exceeding the rated current or an overcurrent caused by a load short-circuit flows for a long time, it may cause smoke and fire. To prevent this, configure an external safety circuit, such as a fuse.
  - Configure a circuit so that the programmable controller is turned on first and then the external power supply. If the external power supply is turned on first, an accident may occur due to an incorrect output or malfunction.
  - For the operating status of each station after a communication failure, refer to manuals relevant to the network. Incorrect output or malfunction due to a communication failure may result in an accident.
  - When connecting an external device with a CPU module or intelligent function module to modify data of a running programmable controller, configure an interlock circuit in the program to ensure that the entire system will always operate safely. For other forms of control (such as program modification, parameter change, forced output, or operating status change) of a running programmable controller, read the relevant manuals carefully and ensure that the operation is safe before proceeding. Improper operation may damage machines or cause accidents.
-

## [Design Precautions]

---

### **WARNING**

- Especially, when a remote programmable controller is controlled by an external device, immediate action cannot be taken if a problem occurs in the programmable controller due to a communication failure. To prevent this, configure an interlock circuit in the program, and determine corrective actions to be taken between the external device and CPU module in case of a communication failure.
  - Do not write any data to the "system area" and "write-protect area" of the buffer memory in the module. Also, do not use any "use prohibited" signals as an output signal from the CPU module to each module. Doing so may cause malfunction of the programmable controller system. For the "system area", "write-protect area", and the "use prohibited" signals, refer to the user's manual for the module used.
  - If a communication cable is disconnected, the network may be unstable, resulting in a communication failure of multiple stations. Configure an interlock circuit in the program to ensure that the entire system will always operate safely even if communications fail. Failure to do so may result in an accident due to an incorrect output or malfunction.
  - To maintain the safety of the programmable controller system against unauthorized access from external devices via the network, take appropriate measures. To maintain the safety against unauthorized access via the Internet, take measures such as installing a firewall.
- 

## [Design Precautions]

---

### **CAUTION**

- Do not install the control lines or communication cables together with the main circuit lines or power cables. Keep a distance of 100mm or more between them. Failure to do so may result in malfunction due to noise.
  - During control of an inductive load such as a lamp, heater, or solenoid valve, a large current (approximately ten times greater than normal) may flow when the output is turned from off to on. Therefore, use a module that has a sufficient current rating.
  - After the CPU module is powered on or is reset, the time taken to enter the RUN status varies depending on the system configuration, parameter settings, and/or program size. Design circuits so that the entire system will always operate safely, regardless of the time.
  - Do not power off the programmable controller or reset the CPU module while the settings are being written. Doing so will make the data in the flash ROM and SD memory card undefined. The values need to be set in the buffer memory and written to the flash ROM and SD memory card again. Doing so also may cause malfunction or failure of the module.
  - When changing the operating status of the CPU module from external devices (such as the remote RUN/STOP functions), select "Do Not Open by Program" for "Opening Method" of "Module Parameter". If "Open by Program" is selected, an execution of the remote STOP function causes the communication line to close. Consequently, the CPU module cannot reopen the line, and external devices cannot execute the remote RUN function.
-

## [Installation Precautions]

---

### **WARNING**

- Shut off the external power supply (all phases) used in the system before mounting or removing the module. Failure to do so may result in electric shock or cause the module to fail or malfunction.
- 

## [Installation Precautions]

---

### **CAUTION**

- Use the programmable controller in an environment that meets the general specifications in the Safety Guidelines included with the base unit. Failure to do so may result in electric shock, fire, malfunction, or damage to or deterioration of the product.
  - To mount a module, place the concave part(s) located at the bottom onto the guide(s) of the base unit, and push in the module until the hook(s) located at the top snaps into place. Incorrect interconnection may cause malfunction, failure, or drop of the module.
  - To mount a module with no module fixing hook, place the concave part(s) located at the bottom onto the guide(s) of the base unit, push in the module, and fix it with screw(s). Incorrect interconnection may cause malfunction, failure, or drop of the module.
  - When using the programmable controller in an environment of frequent vibrations, fix the module with a screw.
  - Tighten the screws within the specified torque range. Undertightening can cause drop of the screw, short circuit, or malfunction. Overtightening can damage the screw and/or module, resulting in drop, short circuit, or malfunction.
  - When using an extension cable, connect it to the extension cable connector of the base unit securely. Check the connection for looseness. Poor contact may cause malfunction.
  - When using an SD memory card, fully insert it into the SD memory card slot. Check that it is inserted completely. Poor contact may cause malfunction.
  - Securely insert an extended SRAM cassette or a battery-less option cassette into the cassette connector of the CPU module. After insertion, close the cassette cover and check that the cassette is inserted completely. Poor contact may cause malfunction.
  - Do not directly touch any conductive parts and electronic components of the module, SD memory card, extended SRAM cassette, battery-less option cassette, or connector. Doing so can cause malfunction or failure of the module.
- 

## [Wiring Precautions]

---

### **WARNING**

- Shut off the external power supply (all phases) used in the system before installation and wiring. Failure to do so may result in electric shock or cause the module to fail or malfunction.
  - After installation and wiring, attach the included terminal cover to the module before turning it on for operation. Failure to do so may result in electric shock.
-

## [Wiring Precautions]

---

### CAUTION

- Individually ground the FG and LG terminals of the programmable controller with a ground resistance of 100 ohm or less. Failure to do so may result in electric shock or malfunction.
  - Use applicable solderless terminals and tighten them within the specified torque range. If any spade solderless terminal is used, it may be disconnected when the terminal screw comes loose, resulting in failure.
  - Check the rated voltage and signal layout before wiring to the module, and connect the cables correctly. Connecting a power supply with a different voltage rating or incorrect wiring may cause fire or failure.
  - Connectors for external devices must be crimped or pressed with the tool specified by the manufacturer, or must be correctly soldered. Incomplete connections may cause short circuit, fire, or malfunction.
  - Securely connect the connector to the module. Poor contact may cause malfunction.
  - Do not install the control lines or communication cables together with the main circuit lines or power cables. Keep a distance of 100mm or more between them. Failure to do so may result in malfunction due to noise.
  - Place the cables in a duct or clamp them. If not, dangling cables may swing or inadvertently be pulled, resulting in malfunction or damage to modules or cables. In addition, the weight of the cables may put stress on modules in an environment of strong vibrations and shocks. Do not clamp the extension cables with the jacket stripped. Doing so may change the characteristics of the cables, resulting in malfunction.
  - Check the interface type and correctly connect the cable. Incorrect wiring (connecting the cable to an incorrect interface) may cause failure of the module and external device.
  - Tighten the terminal screws or connector screws within the specified torque range. Undertightening can cause drop of the screw, short circuit, fire, or malfunction. Overtightening can damage the screw and/or module, resulting in drop, short circuit, fire, or malfunction.
  - When disconnecting the cable from the module, do not pull the cable by the cable part. For the cable with connector, hold the connector part of the cable. For the cable connected to the terminal block, loosen the terminal screw. Pulling the cable connected to the module may result in malfunction or damage to the module or cable.
  - Prevent foreign matter such as dust or wire chips from entering the module. Such foreign matter can cause a fire, failure, or malfunction.
  - A protective film is attached to the top of the module to prevent foreign matter, such as wire chips, from entering the module during wiring. Do not remove the film during wiring. Remove it for heat dissipation before system operation.
  - Programmable controllers must be installed in control panels. Connect the main power supply to the power supply module in the control panel through a relay terminal block. Wiring and replacement of a power supply module must be performed by qualified maintenance personnel with knowledge of protection against electric shock. For wiring, refer to the MELSEC iQ-R Module Configuration Manual.
  - For Ethernet cables to be used in the system, select the ones that meet the specifications in the user's manual for the module used. If not, normal data transmission is not guaranteed.
-

## [Startup and Maintenance Precautions]

---

### **WARNING**

---

- Do not touch any terminal while power is on. Doing so will cause electric shock or malfunction.
  - Correctly connect the battery connector. Do not charge, disassemble, heat, short-circuit, solder, or throw the battery into the fire. Also, do not expose it to liquid or strong shock. Doing so will cause the battery to produce heat, explode, ignite, or leak, resulting in injury and fire.
  - Shut off the external power supply (all phases) used in the system before cleaning the module or retightening the terminal screws, connector screws, or module fixing screws. Failure to do so may result in electric shock.
-



## [Startup and Maintenance Precautions]

---

### CAUTION

- When connecting an external device with a CPU module or intelligent function module to modify data of a running programmable controller, configure an interlock circuit in the program to ensure that the entire system will always operate safely. For other forms of control (such as program modification, parameter change, forced output, or operating status change) of a running programmable controller, read the relevant manuals carefully and ensure that the operation is safe before proceeding. Improper operation may damage machines or cause accidents.
  - Especially, when a remote programmable controller is controlled by an external device, immediate action cannot be taken if a problem occurs in the programmable controller due to a communication failure. To prevent this, configure an interlock circuit in the program, and determine corrective actions to be taken between the external device and CPU module in case of a communication failure.
  - Do not disassemble or modify the modules. Doing so may cause failure, malfunction, injury, or a fire.
  - Use any radio communication device such as a cellular phone or PHS (Personal Handy-phone System) more than 25cm away in all directions from the programmable controller. Failure to do so may cause malfunction.
  - Shut off the external power supply (all phases) used in the system before mounting or removing the module. Failure to do so may cause the module to fail or malfunction.
  - Tighten the screws within the specified torque range. Undertightening can cause drop of the component or wire, short circuit, or malfunction. Overtightening can damage the screw and/or module, resulting in drop, short circuit, or malfunction.
  - After the first use of the product, do not perform each of the following operations more than 50 times (IEC 61131-2/JIS B 3502 compliant). Exceeding the limit may cause malfunction.
    - Mounting/removing the module to/from the base unit
    - Inserting/removing the extended SRAM cassette or battery-less option cassette to/from the CPU module
    - Mounting/removing the terminal block to/from the module
  - After the first use of the product, do not insert/remove the SD memory card to/from the CPU module more than 500 times. Exceeding the limit may cause malfunction.
  - Do not touch the metal terminals on the back side of the SD memory card. Doing so may cause malfunction or failure of the module.
  - Do not touch the integrated circuits on the circuit board of an extended SRAM cassette or a battery-less option cassette. Doing so may cause malfunction or failure of the module.
  - Do not drop or apply shock to the battery to be installed in the module. Doing so may damage the battery, causing the battery fluid to leak inside the battery. If the battery is dropped or any shock is applied to it, dispose of it without using.
  - Startup and maintenance of a control panel must be performed by qualified maintenance personnel with knowledge of protection against electric shock. Lock the control panel so that only qualified maintenance personnel can operate it.
-

## [Startup and Maintenance Precautions]

---

### CAUTION

- Before handling the module, touch a conducting object such as a grounded metal to discharge the static electricity from the human body. Failure to do so may cause the module to fail or malfunction.
- 

## [Operating Precautions]

---

### CAUTION

- When changing data and operating status, and modifying program of the running programmable controller from an external device such as a personal computer connected to an intelligent function module, read relevant manuals carefully and ensure the safety before operation. Incorrect change or modification may cause system malfunction, damage to the machines, or accidents.
  - Do not power off the programmable controller or reset the CPU module while the setting values in the buffer memory are being written to the flash ROM in the module. Doing so will make the data in the flash ROM and SD memory card undefined. The values need to be set in the buffer memory and written to the flash ROM and SD memory card again. Doing so can cause malfunction or failure of the module.
- 

## [Disposal Precautions]

---

### CAUTION

- When disposing of this product, treat it as industrial waste.
  - When disposing of batteries, separate them from other wastes according to the local regulations. For details on battery regulations in EU member states, refer to the MELSEC iQ-R Module Configuration Manual.
- 

## [Transportation Precautions]

---

### CAUTION

- When transporting lithium batteries, follow the transportation regulations. For details on the regulated models, refer to the MELSEC iQ-R Module Configuration Manual.
  - The halogens (such as fluorine, chlorine, bromine, and iodine), which are contained in a fumigant used for disinfection and pest control of wood packaging materials, may cause failure of the product. Prevent the entry of fumigant residues into the product or consider other methods (such as heat treatment) instead of fumigation. The disinfection and pest control measures must be applied to unprocessed raw wood.
-

# CONDITIONS OF USE FOR THE PRODUCT

---

(1) Mitsubishi programmable controller ("the PRODUCT") shall be used in conditions;

- i) where any problem, fault or failure occurring in the PRODUCT, if any, shall not lead to any major or serious accident; and
- ii) where the backup and fail-safe function are systematically or automatically provided outside of the PRODUCT for the case of any problem, fault or failure occurring in the PRODUCT.

(2) The PRODUCT has been designed and manufactured for the purpose of being used in general industries.

MITSUBISHI SHALL HAVE NO RESPONSIBILITY OR LIABILITY (INCLUDING, BUT NOT LIMITED TO ANY AND ALL RESPONSIBILITY OR LIABILITY BASED ON CONTRACT, WARRANTY, TORT, PRODUCT LIABILITY) FOR ANY INJURY OR DEATH TO PERSONS OR LOSS OR DAMAGE TO PROPERTY CAUSED BY the PRODUCT THAT ARE OPERATED OR USED IN APPLICATION NOT INTENDED OR EXCLUDED BY INSTRUCTIONS, PRECAUTIONS, OR WARNING CONTAINED IN MITSUBISHI'S USER, INSTRUCTION AND/OR SAFETY MANUALS, TECHNICAL BULLETINS AND GUIDELINES FOR the PRODUCT.

("Prohibited Application")

Prohibited Applications include, but not limited to, the use of the PRODUCT in;

- Nuclear Power Plants and any other power plants operated by Power companies, and/or any other cases in which the public could be affected if any problem or fault occurs in the PRODUCT.
- Railway companies or Public service purposes, and/or any other cases in which establishment of a special quality assurance system is required by the Purchaser or End User.
- Aircraft or Aerospace, Medical applications, Train equipment, transport equipment such as Elevator and Escalator, Incineration and Fuel devices, Vehicles, Manned transportation, Equipment for Recreation and Amusement, and Safety devices, handling of Nuclear or Hazardous Materials or Chemicals, Mining and Drilling, and/or other applications where there is a significant risk of injury to the public or property.

Notwithstanding the above restrictions, Mitsubishi may in its sole discretion, authorize use of the PRODUCT in one or more of the Prohibited Applications, provided that the usage of the PRODUCT is limited only for the specific applications agreed to by Mitsubishi and provided further that no special quality assurance or fail-safe, redundant or other safety features which exceed the general specifications of the PRODUCTS are required. For details, please contact the Mitsubishi representative in your region.

# INTRODUCTION

---

Thank you for purchasing the Mitsubishi Electric MELSEC iQ-R series programmable controllers.

This manual describes the procedures, system configuration, and troubleshooting of the relevant products listed below.

Before using this product, please read this manual and the relevant manuals carefully and develop familiarity with the functions and performance of the MELSEC iQ-R series programmable controller to handle the product correctly.

Please make sure that the end users read this manual.

## Relevant products

RX10, RX10-TS, RX28, RX40C7, RX40C7-TS, RX41C4, RX41C4-TS, RX42C4, RX40PC6H, RX40NC6H, RX41C6HS, RX61C6HS, RX70C4, RX71C4, RX72C4, RY10R2, RY10R2-TS, RY18R2A, RY20S6, RY40NT5P, RY40NT5P-TS, RY41NT2P, RY41NT2P-TS, RY41NT2H, RY42NT2P, RY40PT5P, RY40PT5P-TS, RY41PT1P, RY41PT1P-TS, RY41PT2H, RY42PT1P, RH42C4NT2P, RG60

# COMPLIANCE WITH EMC AND LOW VOLTAGE DIRECTIVES

---

## Method of ensuring compliance

To ensure that Mitsubishi Electric programmable controllers maintain EMC and Low Voltage Directives when incorporated into other machinery or equipment, certain measures may be necessary. Please refer to one of the following manuals.

- MELSEC iQ-R Module Configuration Manual
- Safety Guidelines (This manual is included with the base unit.)

The CE mark on the side of the programmable controller indicates compliance with EMC and Low Voltage Directives.

## Additional measures

No additional measures are necessary for the compliance of this product with EMC and Low Voltage Directives.

# CONTENTS

SAFETY PRECAUTIONS .....	1
CONDITIONS OF USE FOR THE PRODUCT .....	9
INTRODUCTION .....	10
COMPLIANCE WITH EMC AND LOW VOLTAGE DIRECTIVES .....	10
RELEVANT MANUALS .....	13
TERMS .....	13
GENERIC TERMS AND ABBREVIATIONS .....	13
<b>CHAPTER 1 PRODUCT LISTS</b> .....	<b>14</b>
1.1 Product Lists .....	14
1.2 Reading a Model Name .....	17
<b>CHAPTER 2 PART NAMES</b> .....	<b>19</b>
<b>CHAPTER 3 SPECIFICATIONS</b> .....	<b>21</b>
3.1 Performance Specifications .....	21
Input modules .....	21
Output modules .....	51
I/O combined module .....	84
Blank cover module .....	87
3.2 Function List .....	88
3.3 Buffer Memory .....	88
<b>CHAPTER 4 PROCEDURES BEFORE OPERATION</b> .....	<b>89</b>
<b>CHAPTER 5 SYSTEM CONFIGURATION</b> .....	<b>91</b>
5.1 System Configuration .....	91
5.2 Applicable Systems .....	93
Compatible software version .....	93
<b>CHAPTER 6 INSTALLATION AND WIRING</b> .....	<b>94</b>
6.1 Before Using the I/O Modules .....	94
Input modules .....	94
Output modules .....	95
I/O combined module .....	103
6.2 Wiring .....	104
18-point screw terminal block type module .....	104
40-pin connector type module .....	105
Spring clamp terminal block (lever type) .....	106
6.3 Input Wiring Examples .....	108
<b>CHAPTER 7 PARAMETER SETTINGS</b> .....	<b>110</b>
7.1 Parameter Setting Procedure .....	110
Input response time setting .....	111
Interrupt setting .....	112
Setting of error-time output mode .....	113
Refresh setting .....	114

<b>CHAPTER 8</b>	<b>FUNCTIONS</b>	<b>115</b>
8.1	Input Response Time Setting	115
8.2	Interrupt Input Function	116
8.3	In-Error Output Mode Setting	117
8.4	Output ON Number Count Function	118
<b>CHAPTER 9</b>	<b>TROUBLESHOOTING</b>	<b>119</b>
9.1	Troubleshooting	119
	The RUN LED is not on.	119
	The I/O status indicator LED is not on.	119
9.2	Input Circuit Troubles and Corrective Actions	120
9.3	Output Circuit Troubles and Corrective Actions	123
<b>APPENDICES</b>		<b>129</b>
<b>Appendix 1</b>	<b>Optional Items</b>	<b>129</b>
	Connector/terminal block converter modules	129
	Relay terminal module (A6TE2-16SRN)	134
	Connector-equipped dedicated cables	135
	Spring clamp terminal block	135
	Converter module and interface module (FA goods)	135
<b>Appendix 2</b>	<b>Compatibility of MELSEC iQ-R series I/O Modules with MELSEC Q/L Series I/O Modules</b>	<b>136</b>
<b>Appendix 3</b>	<b>External Dimensions</b>	<b>137</b>
	I/O module, blank cover module	137
	Connectors	141
	Connector/terminal block converter modules	142
	Cable for connector/terminal block converter module	143
<b>INDEX</b>		<b>144</b>
REVISIONS		146
WARRANTY		147
TRADEMARKS		148

# RELEVANT MANUALS

## User's manuals relevant to the module

Manual name [manual number]	Description	Available form
MELSEC iQ-R I/O Module User's Manual [SH-081247ENG] (this manual)	Specifications, procedures before operation, system configuration, wiring, functions, and troubleshooting of the I/O module	Print book e-Manual PDF
Relay Terminal Module User's Manual (Hardware) A6TE2-16SRN [IB-66833, 13JL53]	Performance specifications, part names, external dimensions, wiring, and installation of the A6TE2-16SRN relay terminal module	Print book PDF
Before Using the Product [BCN-P5999-0209]	Compatible models, specifications, and installation procedure of the Q6TE-18SN spring clamp terminal block	Print book PDF

This manual does not include detailed information on the following:

- General specifications
- Applicable combinations of CPU modules and the other modules, and the number of mountable modules
- Installation

For details, refer to the following.

 MELSEC iQ-R Module Configuration Manual

This manual does not include information on the module FB.

For details on the module FB, refer to the Function Block Reference for the module used.

### Point

e-Manual refers to the Mitsubishi Electric FA electronic book manuals that can be browsed using a dedicated tool.

e-Manual has the following features:

- Required information can be cross-searched in multiple manuals.
- Other manuals can be accessed from the links in the manual.
- The hardware specifications of each part can be found from the product figures.
- Pages that users often browse can be bookmarked.

## TERMS

Unless otherwise specified, this manual uses the following terms.

Term	Description
Engineering tool	A tool used for setting up programmable controllers, programming, debugging, and maintenance

## GENERIC TERMS AND ABBREVIATIONS

Unless otherwise specified, this manual uses the following generic terms and abbreviations.

Generic term and abbreviation	Description
CPU module	A generic term for the MELSEC iQ-R series CPU modules
L series	The abbreviation for the Mitsubishi programmable controller MELSEC-L series
Power supply module	A generic term for the MELSEC iQ-R series power supply modules
Q series	The abbreviation for the Mitsubishi programmable controller MELSEC-Q series
RCPUC	Another term for the MELSEC iQ-R series CPU module

# 1 PRODUCT LISTS

## 1.1 Product Lists

### Input modules

Module name		Input specifications	Number of occupied I/O points	Current consumption	Weight	Model	Reference
AC input module		Terminal block 100 to 120VAC, 16 points	16 points	110mA	0.18kg	RX10	Page 21 RX10 AC input module
		Spring clamp terminal block 100 to 120VAC, 16 points			0.14kg	RX10-TS	Page 23 RX10-TS AC input module
		Terminal block 100 to 240VAC, 8 points	16 points	90mA	0.18kg	RX28	Page 25 RX28 AC input module
DC input module	Positive/negative common shared type	Terminal block 24VDC, 16 points	16 points	110mA	0.16kg	RX40C7	Page 27 RX40C7 DC input module
		Spring clamp terminal block 24VDC, 16 points			0.12kg	RX40C7-TS	Page 29 RX40C7-TS DC input module
		40-pin connector 24VDC, 32 points	32 points	150mA	0.11kg	RX41C4	Page 31 RX41C4 DC input module
		Spring clamp terminal block 24VDC, 32 points			0.13kg	RX41C4-TS	Page 33 RX41C4-TS DC input module
		40-pin connector (×2) 24VDC, 64 points	64 points	180mA	0.13kg	RX42C4	Page 35 RX42C4 DC input module
		Terminal block 5/12VDC, 16 points	16 points	100mA	0.16kg	RX70C4	Page 37 RX70C4 DC input module
		40-pin connector 5/12VDC, 32 points	32 points	140mA	0.12kg	RX71C4	Page 39 RX71C4 DC input module
		40-pin connector (×2) 5/12VDC, 64 points	64 points	150mA	0.14kg	RX72C4	Page 41 RX72C4 DC input module
DC high-speed input module	Positive common type	Terminal block 24VDC, 16 points	16 points	100mA	0.16kg	RX40PC6H	Page 43 RX40PC6H DC high-speed input module
	Negative common type	Terminal block 24VDC, 16 points	16 points	100mA	0.16kg	RX40NC6H	Page 45 RX40NC6H DC high-speed input module
	Positive/negative common shared type	40-pin connector 24VDC, 32 points	32 points	150mA	0.12kg	RX41C6HS	Page 47 RX41C6HS DC high-speed input module
		40-pin connector 5VDC, 32 points	32 points	150mA	0.12kg	RX61C6HS	Page 49 RX61C6HS DC high-speed input module



## Output modules

Module name		Output specifications	Number of occupied I/O points	Current consumption	Weight	Model	Reference
Contact output module		Terminal block 240VAC/24VDC, 2A/point, 16 points	16 points	450mA	0.22kg	RY10R2	Page 52 RY10R2 contact output module
		Spring clamp terminal block 240VAC/24VDC, 2A/point, 16 points			0.19kg	RY10R2-TS	Page 54 RY10R2-TS contact output module
		Terminal block 240VAC/24VDC, 2A/point, 8 points	16 points	260mA	0.19kg	RY18R2A	Page 56 RY18R2A contact output module (all points independent contact)
Triac output module		Terminal block 100 to 240VAC, 0.6A/point, 16 points	16 points	280mA	0.24kg	RY20S6	Page 58 RY20S6 triac output module
Transistor output module	Sink type	Terminal block 12/24VDC, 0.5A/point, 16 points	16 points	140mA	0.16kg	RY40NT5 P	Page 60 RY40NT5P transistor output module
		Spring clamp terminal block 12/24VDC, 0.5A/point, 16 points			0.12kg	RY40NT5 P-TS	Page 62 RY40NT5P-TS transistor output module
		40-pin connector 12/24VDC, 0.2A/point, 32 points	32 points	180mA	0.11kg	RY41NT2 P	Page 64 RY41NT2P transistor output module
		Spring clamp terminal block 12/24VDC, 0.2A/point, 32 points			0.13kg	RY41NT2 P-TS	Page 66 RY41NT2P-TS transistor output module
		40-pin connector (×2) 12/24VDC, 0.2A/point, 64 points	64 points	250mA	0.13kg	RY42NT2 P	Page 70 RY42NT2P transistor output module
	Source type	Terminal block 12/24VDC, 0.5A/point, 16 points	16 points	130mA	0.16kg	RY40PT5 P	Page 72 RY40PT5P transistor output module
		Spring clamp terminal block 12/24VDC, 0.5A/point, 16 points			0.12kg	RY40PT5 P-TS	Page 74 RY40PT5P-TS transistor output module
		40-pin connector 12/24VDC, 0.1A/point, 32 points	32 points	190mA	0.11kg	RY41PT1 P	Page 76 RY41PT1P transistor output module
		Spring clamp terminal block 12/24VDC, 0.1A/point, 32 points			0.13kg	RY41PT1 P-TS	Page 78 RY41PT1P-TS transistor output module
		40-pin connector (×2) 12/24VDC, 0.1A/point, 64 points	64 points	290mA	0.13kg	RY42PT1 P	Page 82 RY42PT1P transistor output module
Transistor high-speed output module	Sink type	40-pin connector 5/12/24VDC, 0.2A/point, 32 points	32 points	420mA	0.12kg	RY41NT2 H	Page 68 RY41NT2H transistor high-speed output module
	Source type	40-pin connector 5/12/24VDC, 0.2A/point, 32 points	32 points	410mA	0.12kg	RY41PT2 H	Page 80 RY41PT2H transistor high-speed output module

## I/O combined module

Module name	Input specifications	Output specifications	Number of occupied I/O points	Current consumption	Weight	Model	Reference	
DC input/transistor output combined module	<ul style="list-style-type: none"> <li>Input part: Positive/negative common shared type</li> <li>Output part: Sink type</li> </ul>	40-pin connector 24VDC, 32 points	40-pin connector 12 to 24VDC, 0.2A/point, 32 points	32 points	220mA	0.13kg	RH42C4NT2P	Page 85 RH42C4NT2P DC input/transistor output combined module

## Blank cover module

Module name	Application	Number of occupied I/O points	Current consumption	Weight	Model	Reference
Blank cover module	Use this module to prevent dust at a space where an I/O module is not mounted.	16 points*1	—	0.07kg	RG60	Page 87 RG60 blank cover module

\*1 This number can be changed in the I/O assignment setting of the system parameters.

## 1.2 Reading a Model Name

- For the input module

**R X 4 0 P C 6 H - T S**

(1) (2) (3) (5) (6) (7)

- For the output module

**R Y 4 0 N T 5 P - T S**

(1) (2) (4) (5) (6) (7)

- For the I/O combined module

**R H 4 2 C 4 N T 2 P**

(1) (2) (3) (5) (4) (5) (6)

No.	Item	Symbol	Specifications				
			Input module		Output module		
			AC input	DC input	Contact output	Transistor output	Triac output
(1)	Voltage specifications	1	100 to 120VAC	—	24VDC/240VAC	—	—
		2	100 to 240VAC	—	—	—	100 to 240VAC
		4	—	24VDC	—	12 to 24VDC	—
		5	AC48V	DC48V	—	—	—
		6	—	5VDC	—	—	—
		7	—	DC12V	—	DC12V	—

No.	Item	Symbol	Specifications
(2)	Number of I/O points	0	16 points
		1	32 points
		2	64 points
		8	8 points

No.	Item	Symbol	Specifications
(3)	Input type	None	AC input
		PC	DC input (positive common)
		NC	DC input (negative common)
		C	DC input (positive/negative common shared type)

No.	Item	Symbol	Specifications
(4)	Output type	NT	Transistor output (sink type)
		PT	Transistor output (source type)
		R	Contact output
		S	Triac output

No.	Item	Symbol	Specifications				
			Input module		Output module		
			AC input	DC input	Contact output	Transistor output	Triac output
(5)	Current specifications	1	—	—	—	0.1A	—
		2	—	—	2A	0.2A	—
		4	—	4mA	—	—	—
		5	—	—	—	0.5A	—
		6	—	6mA	—	—	0.6A
		7	—	7mA	—	—	—
No.	Item	Symbol	Specifications				
(6)	Extension specifications	A	Independent common				
		P	With the protection function				
		H	DC high-speed input/DC high-speed output				
		HS					
No.	Item	Symbol	Specifications				
(7)	Others	-TS	Spring clamp terminal block type				

# 2 PART NAMES

This section describes the part names of the I/O module.

18-point screw terminal block type

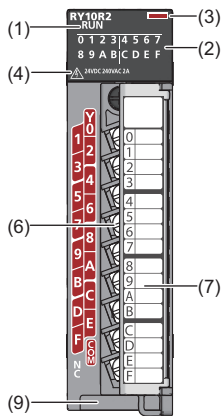

40-pin connector type

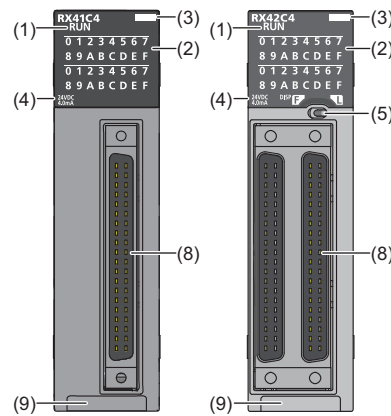

Spring clamp terminal block type

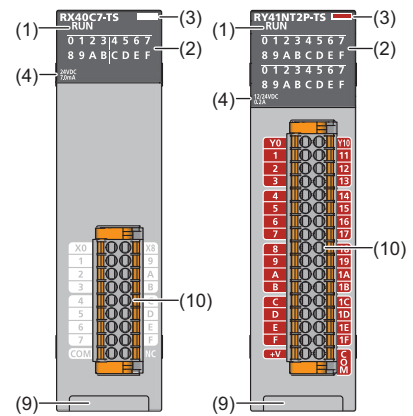

No.	Name	Description
(1)	RUN LED	Indicates the operating status. On: In operation Flashing (400ms cycles): Selected as a module for the online module change Off: 5V power supply interrupted or module replacement allowed in the process of the online module change
(2)	I/O status indicator LED	Indicates the I/O status. On: I/O signal on Off: I/O signal off
(3)	Module identification lamp	Light gray: Input Dark orange: Output
(4)	Rate indication	Indicates the rated voltage, and input current or output current.
(5)	Indication selector switch <sup>*1</sup>	<ul style="list-style-type: none"> <li>For the input module or output module: A switch for changing the LED indication to either the first-half 32 points or the latter-half 32 points of a 64-point module</li> <li>For the I/O combined module: A switch for changing the LED indication for input or output</li> </ul>
(6)	Terminal block	18-point screw terminal block. For the terminal layout, refer to the following. ☞ Page 21 Performance Specifications
(7)	Terminal block cover	Covers for preventing electric shock while the power is on
(8)	Connector for external devices (40 pins)	A connector for connecting I/O signal wire from external devices. For the signal layout, refer to the following. ☞ Page 21 Performance Specifications
(9)	Production information marking	Shows the production information (16 digits) of the module.
(10)	Spring clamp terminal block	Spring clamp terminal block. For the signal layout, refer to the following. ☞ Page 21 Performance Specifications

\*1 Operate the indication selector switch with a finger. If the operation is difficult with a finger, use a pen with a long narrow tip, and others. In this case, be careful not to damage the module. Do not use tools such as a driver because of the possibility of damaging the switch part.

# MEMO

---

# 3 SPECIFICATIONS



This chapter describes the performance specifications.

## 3.1 Performance Specifications

This section describes the performance specifications of the I/O modules.

### Input modules

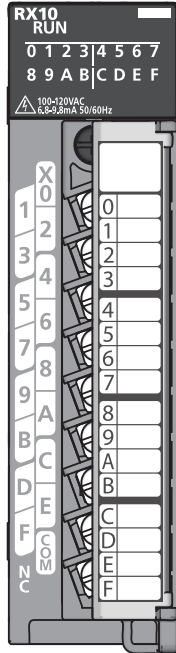
#### RX10 AC input module

Item	Specifications	Appearance	
Number of input points	16 points		
Rated input voltage, frequency	100 to 120VAC (+10%/-15%), 50/60Hz (±3Hz)		
Input voltage distortion ratio	Within 5%		
Rated input current	8.2mA (100VAC, 60Hz), 6.8mA (100VAC, 50Hz)		
Inrush current	200mA maximum within 1ms		
ON voltage/ON current	80VAC or higher/5mA or higher (50Hz, 60Hz)		
OFF voltage/OFF current	30VAC or lower/1.7mA or lower (50Hz, 60Hz)		
Input impedance	12.2kΩ (60Hz), 14.6kΩ (50Hz)		
Response time	OFF→ON		15ms or less (100VAC 50Hz, 60Hz)
	ON→OFF		20ms or less (100VAC 50Hz, 60Hz)
Withstand voltage	1400VACrms, 1 minute		
Isolation resistance	10MΩ or higher by isolation resistance tester		
Noise immunity	Simulator noise 1500Vp-p, noise width 1μs, noise frequency 25 to 60Hz (noise simulator condition)		
Protection degree	IP1X		
Wiring method for common	16 points/common (common terminal: TB17)		
Number of occupied I/O points	16 points (I/O assignment: Input 16 points)		
Interrupt function	Available (can be set in the "Module Parameter")		
External interface	18-point screw terminal block (M3×6 screw)  Page 104 18-point screw terminal block type module		
Internal current consumption (5VDC)	110mA (TYP. all points ON)		
Weight	0.18kg		

#### Derating chart

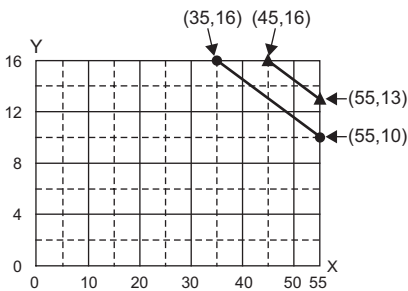

- ▲: Input voltage 120VAC
- : Input voltage 132VAC
- X: Ambient temperature (°C)
- Y: Number of simultaneous on points (point)

## ■Circuit configuration

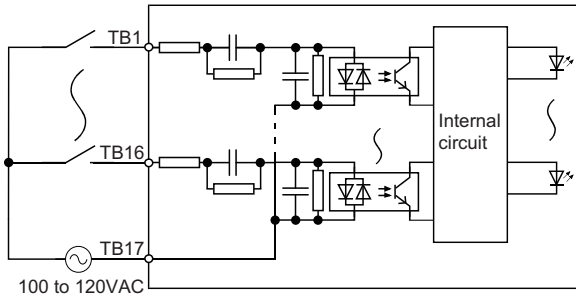

## ■Terminal connection

Connection diagram viewed from the front of the module

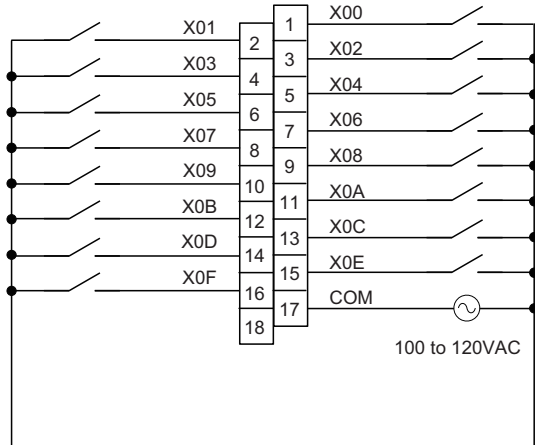

X00 to X0F are signal names.

The number of 1 to 18 indicates a terminal number.

The terminal number 18 is empty.



## RX10-TS AC input module

Item	Specifications	Appearance	
Number of input points	16 points		
Rated input voltage, frequency	100 to 120VAC (+10%/-15%), 50/60Hz (±3Hz)		
Input voltage distortion ratio	Within 5%		
Rated input current	8.2mA (100VAC, 60Hz), 6.8mA (100VAC, 50Hz)		
Inrush current	200mA maximum within 1ms		
ON voltage/ON current	80VAC or higher/5mA or higher (50Hz, 60Hz)		
OFF voltage/OFF current	30VAC or lower/1.7mA or lower (50Hz, 60Hz)		
Input impedance	12.2kΩ (60Hz), 14.6kΩ (50Hz)		
Response time	OFF→ON		15ms or less (100VAC 50Hz, 60Hz)
	ON→OFF		20ms or less (100VAC 50Hz, 60Hz)
Withstand voltage	1400VACrms, 1 minute		
Isolation resistance	10MΩ or higher by isolation resistance tester		
Noise immunity	Simulator noise 1500Vp-p, noise width 1μs, noise frequency 25 to 60Hz (noise simulator condition)		
Protection degree	IP1X		
Wiring method for common	16 points/common (common terminal: 9)		
Number of occupied I/O points	16 points (I/O assignment: Input 16 points)		
Interrupt function	Available (can be set in the "Module Parameter")		
External interface	Two-piece spring clamp terminal block Page 106 Spring clamp terminal block (lever type)		
Internal current consumption (5VDC)	110mA (TYP. all points ON)		
Weight	0.14kg		

3

### Derating chart

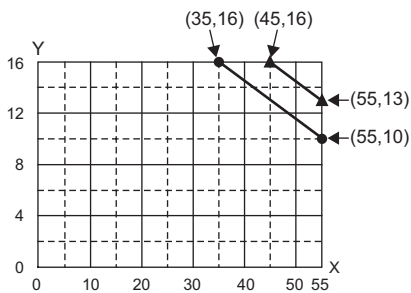

- : Input voltage 120VAC
- ▲: Input voltage 132VAC
- X: Ambient temperature (°C)
- Y: Number of simultaneous on points (point)

## ■Circuit configuration

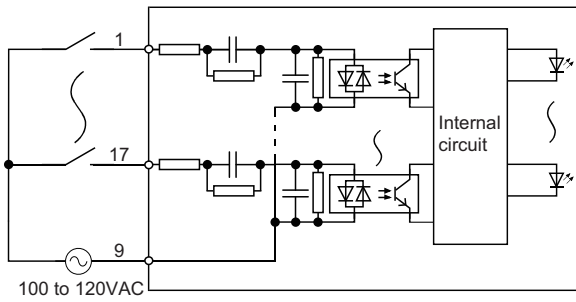

## ■Terminal connection

Connection diagram viewed from the front of the module

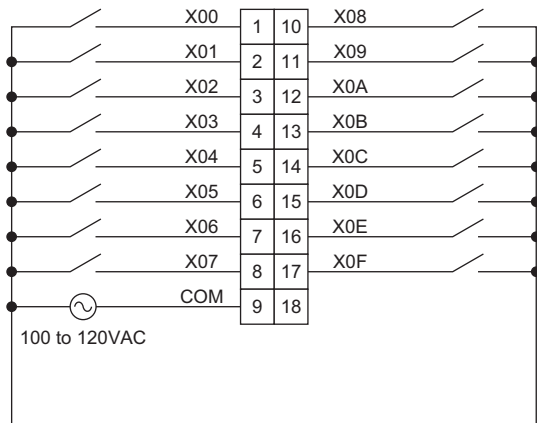

X00 to X0F are signal names.

The number of 1 to 18 indicates a terminal number.

The terminal number 18 is empty.

## RX28 AC input module

Item	Specifications	Appearance	
Number of input points	8 points		
Rated input voltage, frequency	100 to 240VAC (+10%/-15%), 50/60Hz (±3Hz)		
Input voltage distortion ratio	Within 5%		
Rated input current	16.4mA (200VAC, 60Hz) 13.7mA (200VAC, 50Hz) 8.2mA (100VAC, 60Hz) 6.8mA (100VAC, 50Hz)		
Inrush current	950mA maximum within 1ms		
ON voltage/ON current	80VAC or higher/5mA or higher (50Hz, 60Hz)		
OFF voltage/OFF current	30VAC or lower/1.7mA or lower (50Hz, 60Hz)		
Input impedance	12.1kΩ (60Hz), 14.5kΩ (50Hz)		
Response time	OFF→ON		10ms or less (200VAC 50Hz, 60Hz)
	ON→OFF		20ms or less (200VAC 50Hz, 60Hz)
Withstand voltage	2300VACrms, 1 minute		
Isolation resistance	10MΩ or higher by isolation resistance tester		
Noise immunity	Simulator noise 1500Vp-p, noise width 1μs, noise frequency 25 to 60Hz (noise simulator condition)		
Protection degree	IP1X		
Wiring method for common	8 points/common (common terminal: TB17)		
Number of occupied I/O points	16 points (I/O assignment: Input 16 points)		
Interrupt function	Available (can be set in the "Module Parameter")		
External interface	18-point screw terminal block (M3×6 screw) Page 104 18-point screw terminal block type module		
Internal current consumption (5VDC)	90mA (TYP. all points ON)		
Weight	0.18kg		

### Derating chart

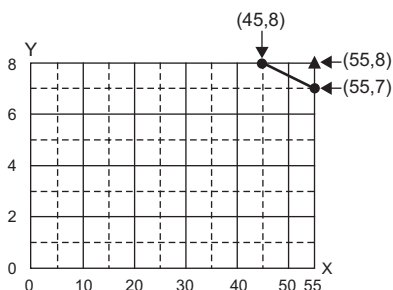

- ▲: Input voltage 240VAC
- : Input voltage 264VAC
- X: Ambient temperature (°C)
- Y: Number of simultaneous on points (point)

### Circuit configuration

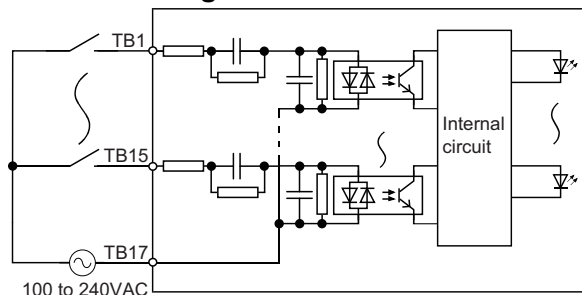

## ■ Terminal connection

Connection diagram viewed from the front of the module

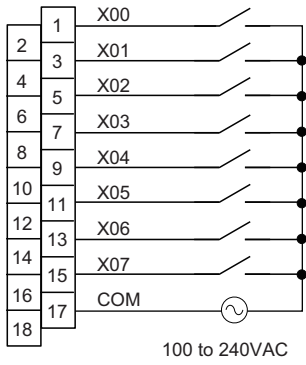

X00 to X07 are signal names.

The number of 1 to 18 indicates a terminal number.

The terminal number 2, 4, 6, 8, 10, 12, 14, 16, and 18 are empty.

## RX40C7 DC input module

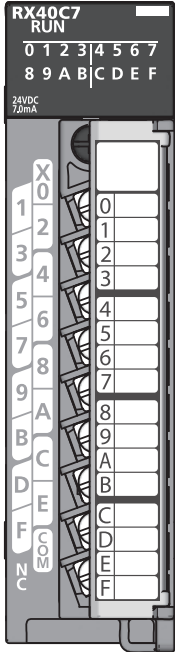
Item	Specifications	Appearance
Number of input points	16 points	
Rated input voltage	24VDC (ripple ratio: within 5%) (allowable voltage range: 20.4 to 28.8VDC)	
Rated input current	7.0mA TYP. (at 24VDC)	
ON voltage/ON current	15V or higher/4mA or higher	
OFF voltage/OFF current	8V or lower/2mA or lower	
Input resistance	3.3kΩ	
Response time	☞ Page 28 Input response time	
Withstand voltage	510VACrms, 1 minute	
Isolation resistance	10MΩ or higher by isolation resistance tester	
Noise immunity	Simulator noise 500Vp-p, noise width 1μs, noise frequency 25 to 60Hz (noise simulator condition)	
Protection degree	IP2X	
Wiring method for common	16 points/common (common terminal: TB17) Positive/negative common shared type	
Number of occupied I/O points	16 points (I/O assignment: Input 16 points)	
Interrupt function	Available (can be set in the "Module Parameter")	
External interface	18-point screw terminal block (M3×6 screw) ☞ Page 104 18-point screw terminal block type module	
Internal current consumption (5VDC)	110mA (TYP. all points ON)	
Weight	0.16kg	

### ■Circuit configuration

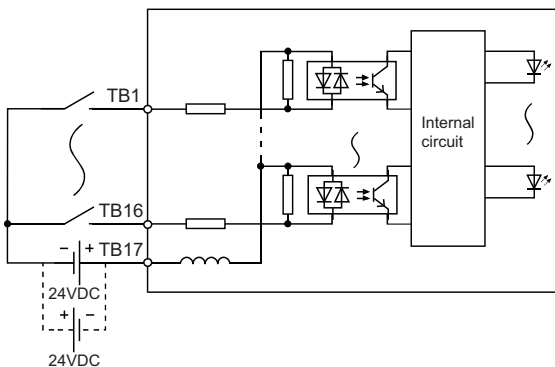

### ■Terminal connection

Connection diagram viewed from the front of the module

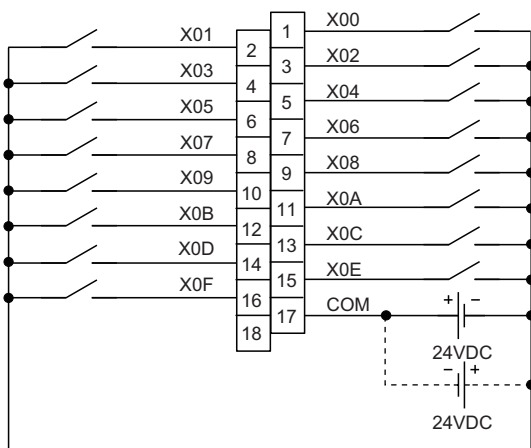

X00 to X0F are signal names.

The number of 1 to 18 indicates a terminal number.

The terminal number 18 is empty.

## ■ Input response time

Timing	Setting value								
	0.1ms	0.2ms	0.4ms	0.6ms	1ms	5ms	10ms <sup>*1</sup>	20ms	70ms
OFF→ON (MAX)	0.1ms	0.2ms	0.4ms	0.6ms	1ms	5ms	10ms	20ms	70ms
ON→OFF (MAX)	0.35ms	0.4ms	0.5ms	0.7ms	1ms	5ms	10ms	20ms	70ms

\*1 The default value of input response time is 10ms.

## RX40C7-TS DC input module

Item	Specifications	Appearance
Number of input points	16 points	
Rated input voltage	24VDC (ripple ratio: within 5%) (allowable voltage range: 20.4 to 28.8VDC)	
Rated input current	7.0mA TYP. (at 24VDC)	
ON voltage/ON current	15V or higher/4mA or higher	
OFF voltage/OFF current	8V or lower/2mA or lower	
Input resistance	3.3kΩ	
Response time	☞ Page 30 Input response time	
Withstand voltage	510VACrms, 1 minute	
Isolation resistance	10MΩ or higher by isolation resistance tester	
Noise immunity	Simulator noise 500Vp-p, noise width 1μs, noise frequency 25 to 60Hz (noise simulator condition)	
Protection degree	IP2X	
Wiring method for common	16 points/common (common terminal: 9) Positive/negative common shared type	
Number of occupied I/O points	16 points (I/O assignment: Input 16 points)	
Interrupt function	Available (can be set in the "Module Parameter")	
External interface	Two-piece spring clamp terminal block ☞ Page 106 Spring clamp terminal block (lever type)	
Internal current consumption (5VDC)	110mA (TYP. all points ON)	
Weight	0.12kg	

### ■ Circuit configuration

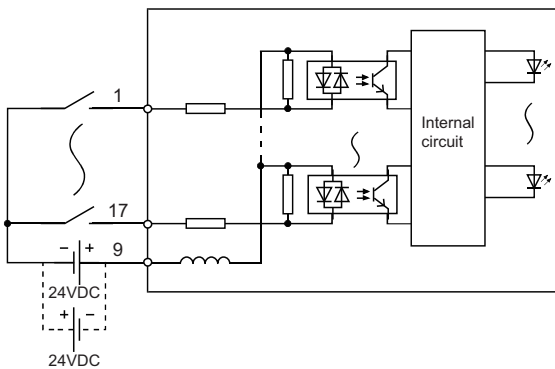

### ■ Terminal connection

Connection diagram viewed from the front of the module

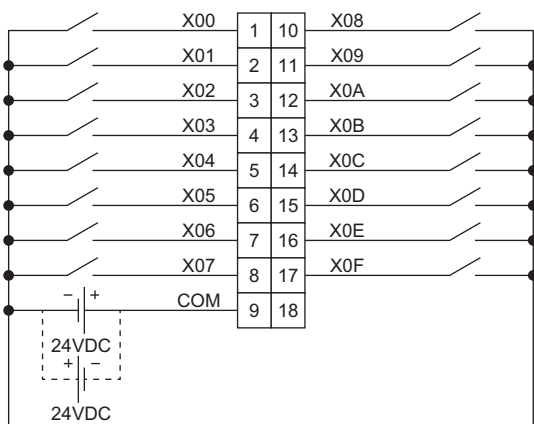

X00 to X0F are signal names.

The number of 1 to 18 indicates a terminal number.

The terminal number 18 is empty.

## ■ Input response time

Timing	Setting value								
	0.1ms	0.2ms	0.4ms	0.6ms	1ms	5ms	10ms <sup>*1</sup>	20ms	70ms
OFF→ON (MAX)	0.1ms	0.2ms	0.4ms	0.6ms	1ms	5ms	10ms	20ms	70ms
ON→OFF (MAX)	0.35ms	0.4ms	0.5ms	0.7ms	1ms	5ms	10ms	20ms	70ms

\*1 The default value of input response time is 10ms.



## RX41C4 DC input module

Item	Specifications	Appearance
Number of input points	32 points	
Rated input voltage	24VDC (ripple ratio: within 5%) (allowable voltage range: 20.4 to 28.8VDC)	
Rated input current	4.0mA TYP. (at 24VDC)	
ON voltage/ON current	19V or higher/3mA or higher	
OFF voltage/OFF current	6V or lower/1.0mA or lower	
Input resistance	5.3kΩ	
Response time	☞ Page 32 Input response time	
Withstand voltage	510VACrms, 1 minute	
Isolation resistance	10MΩ or higher by isolation resistance tester	
Noise immunity	Simulator noise 500Vp-p, noise width 1μs, noise frequency 25 to 60Hz (noise simulator condition)	
Protection degree	IP2X	
Wiring method for common	32 points/common (common terminal: B01, B02) Positive/negative common shared type	
Number of occupied I/O points	32 points (I/O assignment: Input 32 points)	
Interrupt function	Available (can be set in the "Module Parameter")	
External interface	40-pin connector ☞ Page 105 40-pin connector type module	
Internal current consumption (5VDC)	150mA (TYP. all points ON)	
Weight	0.11kg	

3

### Derating chart

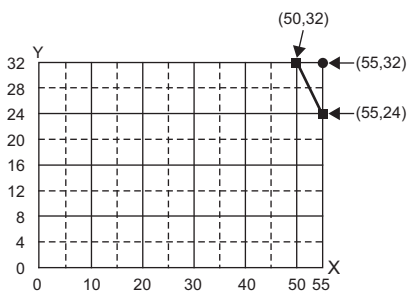

- : Input voltage 26.4VDC
- : Input voltage 28.8VDC
- X: Ambient temperature (°C)
- Y: Number of simultaneous on points (point)

### Circuit configuration

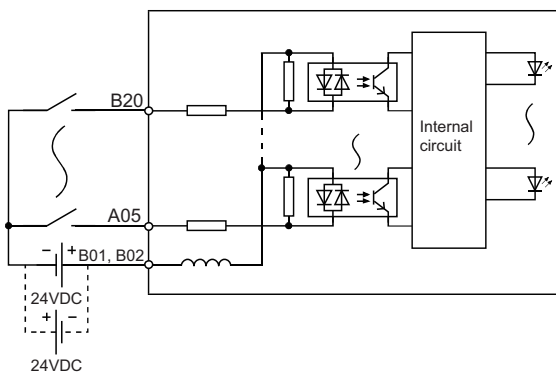

## Terminal connection

Connection diagram viewed from the front of the module

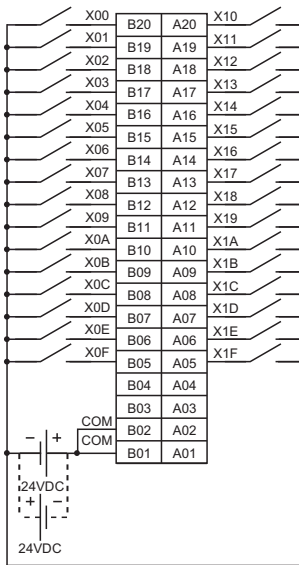

X00 to X1F are signal names.

A01 to A20 and B01 to B20 indicate pin numbers.

A01 to A04, B03, and B04 are empty.

## Input response time

Timing	Setting value									
	0.1ms	0.2ms	0.4ms	0.6ms	1ms	5ms	10ms <sup>*1</sup>	20ms	70ms	
OFF→ON (MAX)	0.1ms	0.2ms	0.4ms	0.6ms	1ms	5ms	10ms	20ms	70ms	
ON→OFF (MAX)	0.2ms	0.3ms	0.5ms	0.7ms	1ms	5ms	10ms	20ms	70ms	

\*1 The default value of input response time is 10ms.

## RX41C4-TS DC input module

Item	Specifications	Appearance
Number of input points	32 points	
Rated input voltage	24VDC (ripple ratio: within 5%) (allowable voltage range: 20.4 to 28.8VDC)	
Rated input current	4.0mA TYP. (at 24VDC)	
ON voltage/ON current	19V or higher/3mA or higher	
OFF voltage/OFF current	6V or lower/1.0mA or lower	
Input resistance	5.3kΩ	
Response time	☞ Page 34 Input response time	
Withstand voltage	510VACrms, 1 minute	
Isolation resistance	10MΩ or higher by isolation resistance tester	
Noise immunity	Simulator noise 500Vp-p, noise width 1μs, noise frequency 25 to 60Hz (noise simulator condition)	
Protection degree	IP2X	
Wiring method for common	32 points/common (common terminal: 17) Positive/negative common shared type	
Number of occupied I/O points	32 points (I/O assignment: Input 32 points)	
Interrupt function	Available (can be set in the "Module Parameter")	
External interface	Two-piece spring clamp terminal block ☞ Page 106 Spring clamp terminal block (lever type)	
Internal current consumption (5VDC)	150mA (TYP. all points ON)	
Weight	0.13kg	

### Derating chart

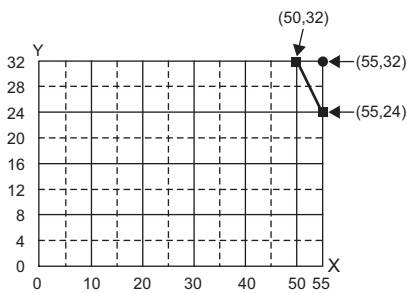

- : Input voltage 26.4VDC
- : Input voltage 28.8VDC
- X: Ambient temperature (°C)
- Y: Number of simultaneous on points (point)

### Circuit configuration

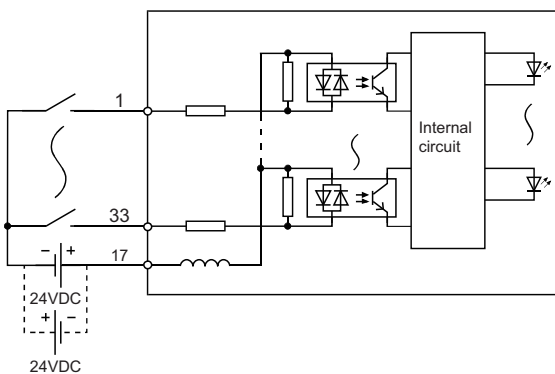

## Terminal connection

Connection diagram viewed from the front of the module

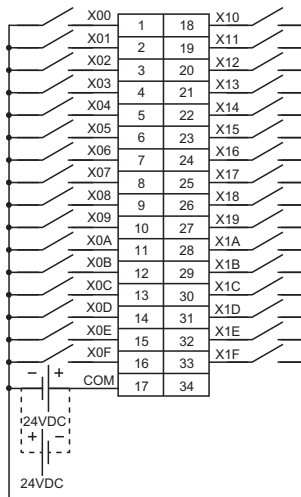

X00 to X1F are signal names.

The number of 1 to 34 indicates a terminal number.

The terminal number 34 is empty.

## Input response time

Timing	Setting value									
	0.1ms	0.2ms	0.4ms	0.6ms	1ms	5ms	10ms <sup>*1</sup>	20ms	70ms	
OFF→ON (MAX)	0.1ms	0.2ms	0.4ms	0.6ms	1ms	5ms	10ms	20ms	70ms	
ON→OFF (MAX)	0.2ms	0.3ms	0.5ms	0.7ms	1ms	5ms	10ms	20ms	70ms	

\*1 The default value of input response time is 10ms.

## RX42C4 DC input module

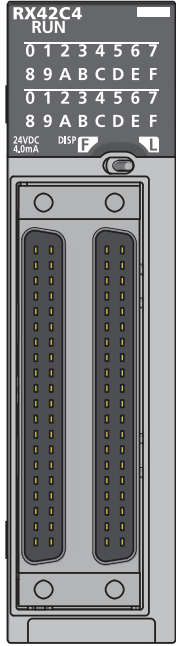
Item	Specifications	Appearance
Number of input points	64 points	
Rated input voltage	24VDC (ripple ratio: within 5%) (allowable voltage range: 20.4 to 28.8VDC)	
Rated input current	4.0mA TYP. (at 24VDC)	
ON voltage/ON current	19V or higher/3mA or higher	
OFF voltage/OFF current	6V or lower/1.0mA or lower	
Input resistance	5.3kΩ	
Response time	☞ Page 36 Input response time	
Withstand voltage	510VACrms, 1 minute	
Isolation resistance	10MΩ or higher by isolation resistance tester	
Noise immunity	Simulator noise 500Vp-p, noise width 1μs, noise frequency 25 to 60Hz (noise simulator condition)	
Protection degree	IP2X	
Wiring method for common	32 points/common (common terminal: 1B01, 1B02, 2B01, 2B02) Positive/negative common shared type	
Number of occupied I/O points	64 points (I/O assignment: Input 64 points)	
Interrupt function	Available (can be set in the "Module Parameter")	
External interface	40-pin connector ☞ Page 105 40-pin connector type module	
Internal current consumption (5VDC)	180mA (TYP. all points ON)	
Weight	0.13kg	

### Derating chart

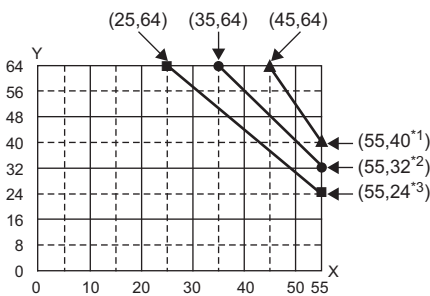

- ▲: Input voltage 24VDC
- : Input voltage 26.4VDC
- : Input voltage 28.8VDC
- X: Ambient temperature (°C)
- Y: Number of simultaneous on points (point)

\*1 This indicates 20 points/common (total 40 points).

\*2 This indicates 16 points/common (total 32 points).

\*3 This indicates 12 points/common (total 24 points).

### Circuit configuration

The figure below shows the case of 32 points in the first half (F). The case of 32 points in the latter half (L) is the same.

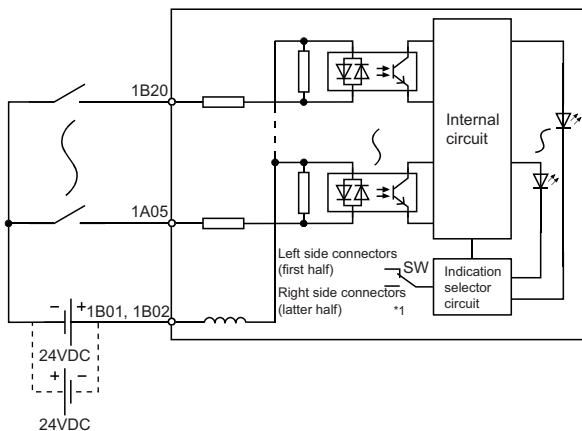

\*1 The LED indicates the first half (X00 to X1F) by turning the switch to the left (F), while the LED indicates the latter half (X20 to X3F) by turning the switch to the right (L).

## Terminal connection

Connection diagram viewed from the front of the module

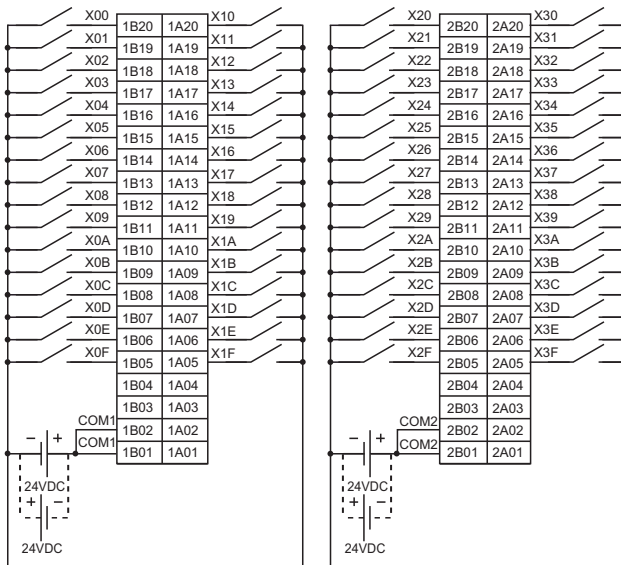

X00 to X1F and X20 to X3F are signal names.

1A01 to 1A20, 1B01 to 1B20, 2A01 to 2A20, and 2B01 to 2B20 indicate pin numbers.

1A01 to 1A04, 1B03, 1B04, 2A01 to 2A04, 2B03, and 2B04 are empty.

## Input response time

Timing	Setting value								
	0.1ms	0.2ms	0.4ms	0.6ms	1ms	5ms	10ms <sup>*1</sup>	20ms	70ms
OFF→ON (MAX)	0.1ms	0.2ms	0.4ms	0.6ms	1ms	5ms	10ms	20ms	70ms
ON→OFF (MAX)	0.2ms	0.3ms	0.5ms	0.7ms	1ms	5ms	10ms	20ms	70ms

\*1 The default value of input response time is 10ms.

## RX70C4 DC input module

Item	Specifications		Appearance
Number of input points	16 points		
Rated input voltage	5VDC (ripple ratio: within 5%) (allowable voltage range: 4.25 to 6VDC)	12VDC (ripple ratio: within 5%) (allowable voltage range: 10.2 to 14.4VDC)	
Rated input current	1.7mA TYP. (at 5VDC)	4.8mA TYP. (at 12VDC)	
ON voltage/ON current	3.5V or higher/1mA or higher		
OFF voltage/OFF current	1V or lower/0.1mA or lower		
Input resistance	2.3k $\Omega$		
Response time	☞ Page 38 Input response time		
Withstand voltage	510VACrms, 1 minute		
Isolation resistance	10M $\Omega$ or higher by isolation resistance tester		
Noise immunity	Simulator noise 500Vp-p, noise width 1 $\mu$ s, noise frequency 25 to 60Hz (noise simulator condition)		
Protection degree	IP2X		
Wiring method for common	16 points/common (common terminal: TB17) Positive/negative common shared type		
Number of occupied I/O points	16 points (I/O assignment: Input 16 points)		
Interrupt function	Available (can be set in the "Module Parameter")		
External interface	18-point screw terminal block (M3 $\times$ 6 screw) ☞ Page 104 18-point screw terminal block type module		
Internal current consumption (5VDC)	100mA (TYP. all points ON)		
Weight	0.16kg		

### ■ Circuit configuration

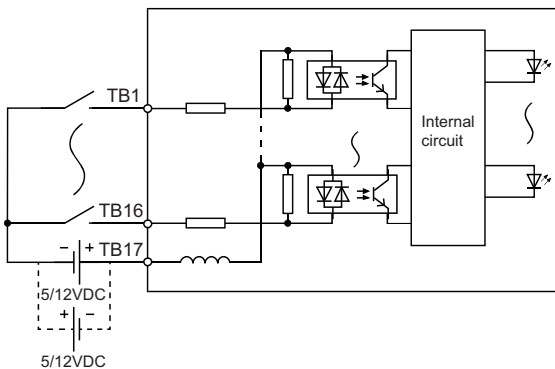

## Terminal connection

Connection diagram viewed from the front of the module

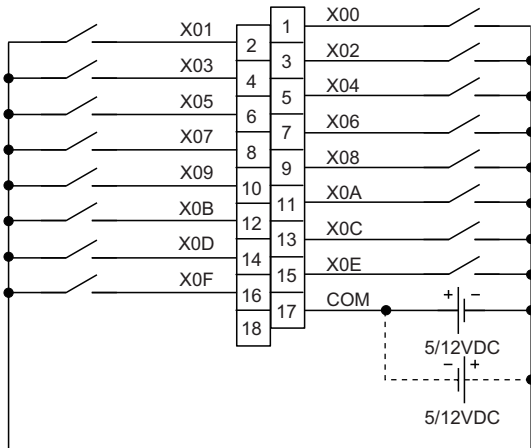

X00 to X0F are signal names.

The number of 1 to 18 indicates a terminal number.

The terminal number 18 is empty.

## Input response time

Timing	Setting value								
	0.1ms	0.2ms	0.4ms	0.6ms	1ms	5ms	10ms <sup>*1</sup>	20ms	70ms
OFF→ON (MAX)	0.2ms	0.3ms	0.4ms	0.5ms	1ms	5ms	10ms	20ms	70ms
ON→OFF (MAX)	0.41ms	0.5ms	0.6ms	0.7ms	1ms	5ms	10ms	20ms	70ms

\*1 The default value of input response time is 10ms.



## RX71C4 DC input module

Item	Specifications		Appearance
Number of input points	32 points		
Rated input voltage	5VDC (ripple ratio: within 5%) (allowable voltage range: 4.25 to 6VDC)	12VDC (ripple ratio: within 5%) (allowable voltage range: 10.2 to 14.4VDC)	
Rated input current	1.7mA TYP. (at 5VDC)	4.8mA TYP. (at 12VDC)	
ON voltage/ON current	3.5V or higher/1mA or higher		
OFF voltage/OFF current	1V or lower/0.1mA or lower		
Input resistance	2.3k $\Omega$		
Response time	☞ Page 40 Input response time		
Withstand voltage	510VACrms, 1 minute		
Isolation resistance	10M $\Omega$ or higher by isolation resistance tester		
Noise immunity	Simulator noise 500Vp-p, noise width 1 $\mu$ s, noise frequency 25 to 60Hz (noise simulator condition)		
Protection degree	IP2X		
Wiring method for common	32 points/common (common terminal: B01, B02) Positive/negative common shared type		
Number of occupied I/O points	32 points (I/O assignment: Input 32 points)		
Interrupt function	Available (can be set in the "Module Parameter")		
External interface	40-pin connector ☞ Page 105 40-pin connector type module		
Internal current consumption (5VDC)	140mA (TYP. all points ON)		
Weight	0.12kg		

### ■ Circuit configuration

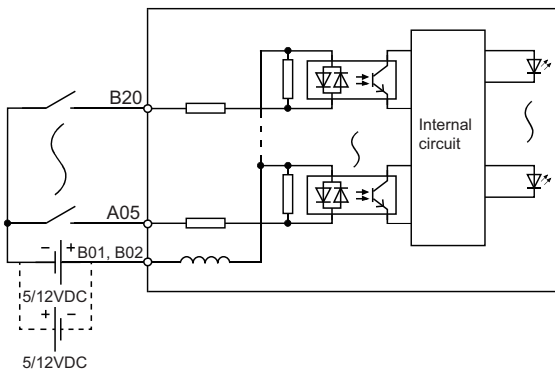

## Terminal connection

Connection diagram viewed from the front of the module

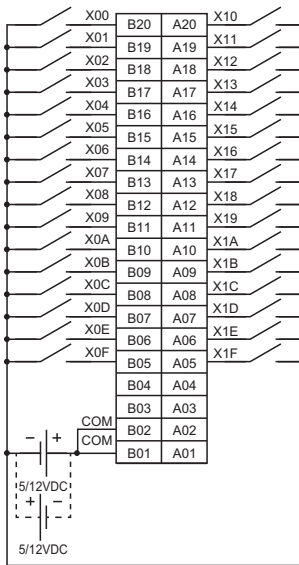

X00 to X1F are signal names.

A01 to A20 and B01 to B20 indicate pin numbers.

A01 to A04, B03, and B04 are empty.

## Input response time

Timing	Setting value									
	0.1ms	0.2ms	0.4ms	0.6ms	1ms	5ms	10ms <sup>*1</sup>	20ms	70ms	
OFF→ON (MAX)	0.2ms	0.3ms	0.5ms	0.6ms	1ms	5ms	10ms	20ms	70ms	
ON→OFF (MAX)	0.21ms	0.3ms	0.5ms	0.6ms	1ms	5ms	10ms	20ms	70ms	

\*1 The default value of input response time is 10ms.

## RX72C4 DC input module

Item	Specifications		Appearance
Number of input points	64 points		
Rated input voltage	5VDC (ripple ratio: within 5%) (allowable voltage range: 4.25 to 6VDC)	12VDC (ripple ratio: within 5%) (allowable voltage range: 10.2 to 14.4VDC)	
Rated input current	1.7mA TYP. (at 5VDC)	4.8mA TYP. (at 12VDC)	
ON voltage/ON current	3.5V or higher/1mA or higher		
OFF voltage/OFF current	1V or lower/0.1mA or lower		
Input resistance	2.3k $\Omega$		
Response time	☞ Page 42 Input response time		
Withstand voltage	510VACrms, 1 minute		
Isolation resistance	10M $\Omega$ or higher by isolation resistance tester		
Noise immunity	Simulator noise 500Vp-p, noise width 1 $\mu$ s, noise frequency 25 to 60Hz (noise simulator condition)		
Protection degree	IP2X		
Wiring method for common	32 points/common (common terminal: 1B01, 1B02, 2B01, 2B02) Positive/negative common shared type		
Number of occupied I/O points	64 points (I/O assignment: Input 64 points)		
Interrupt function	Available (can be set in the "Module Parameter")		
External interface	40-pin connector ☞ Page 105 40-pin connector type module		
Internal current consumption (5VDC)	150mA (TYP. all points ON)		
Weight	0.14kg		

3

### ■ Circuit configuration

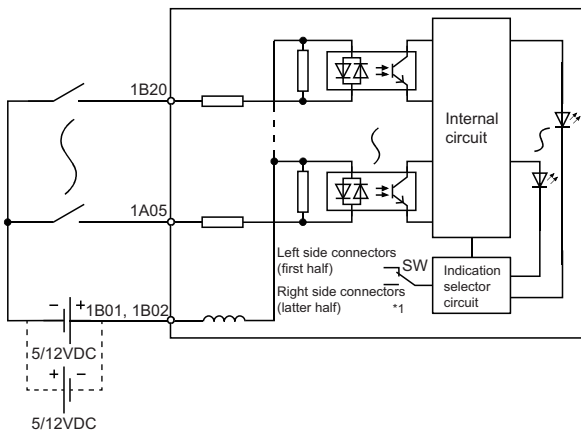

\*1 The figure above shows the case of 32 points in the first half (F). The case of 32 points in the latter half (L) is the same.

## Terminal connection

Connection diagram viewed from the front of the module

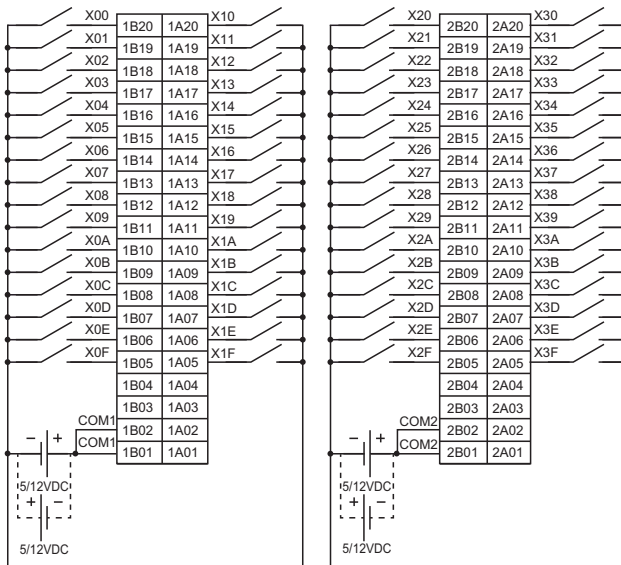

X00 to X1F and X20 to X3F are signal names.

1A01 to 1A20, 1B01 to 1B20, 2A01 to 2A20, and 2B01 to 2B20 indicate pin numbers.

1A01 to 1A04, 1B03, 1B04, 2A01 to 2A04, 2B03, and 2B04 are empty.

## Input response time

Timing	Setting value									
	0.1ms	0.2ms	0.4ms	0.6ms	1ms	5ms	10ms <sup>*1</sup>	20ms	70ms	
OFF→ON (MAX)	0.2ms	0.3ms	0.5ms	0.6ms	1ms	5ms	10ms	20ms	70ms	
ON→OFF (MAX)	0.21ms	0.3ms	0.5ms	0.6ms	1ms	5ms	10ms	20ms	70ms	

\*1 The default value of input response time is 10ms.

## RX40PC6H DC high-speed input module

Item	Specifications	Appearance
Number of input points	16 points	
Rated input voltage	24VDC (ripple ratio: within 5%) (allowable voltage range: 20.4 to 28.8VDC)	
Rated input current	6.0mA TYP. (at 24VDC)	
ON voltage/ON current	15V or higher/4mA or higher	
OFF voltage/OFF current	8V or lower/1.7mA or lower	
Input resistance	3.9kΩ	
Response time	☞ Page 44 Input response time	
Withstand voltage	510VACrms, 1 minute	
Isolation resistance	10MΩ or higher by isolation resistance tester	
Noise immunity*1	Simulator noise 500Vp-p, noise width 1μs, noise frequency 25 to 60Hz (noise simulator condition)	
Protection degree	IP2X	
Wiring method for common	8 points/common (common terminal: TB9, TB18) Positive common type	
Number of occupied I/O points	16 points (I/O assignment: Input 16 points)	
Interrupt function	Available (can be set in the "Module Parameter")	
External interface	18-point screw terminal block (M3×6 screw) ☞ Page 104 18-point screw terminal block type module	
Internal current consumption (5VDC)	100mA (TYP. all points ON)	
Weight	0.16kg	

\*1 The noise immunity is the value for when the input response time setting is set to 50μs or longer.

### Derating chart

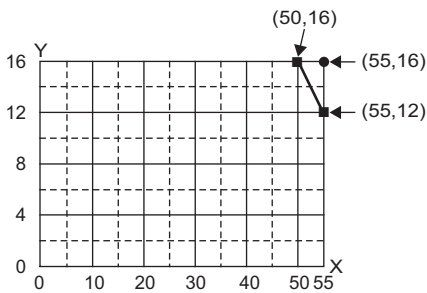

- : Input voltage 26.4VDC
- : Input voltage 28.8VDC
- X: Ambient temperature (°C)
- Y: Number of simultaneous on points (point)

### Circuit configuration

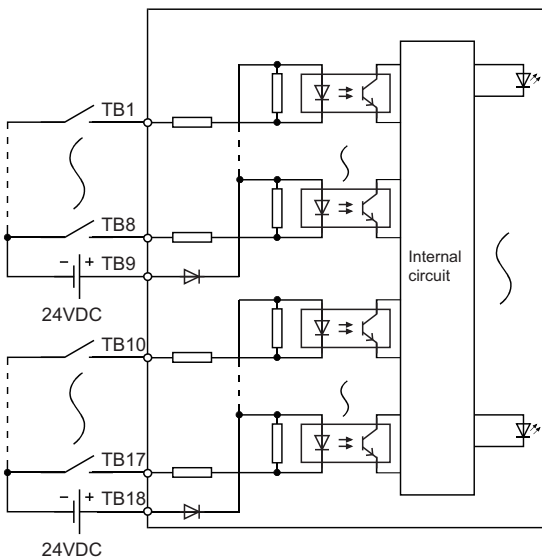

## Terminal connection

Connection diagram viewed from the front of the module

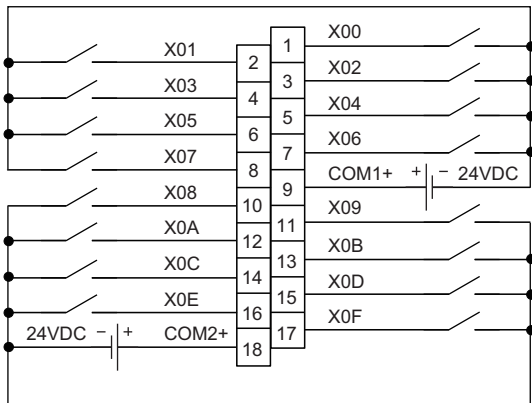

X00 to X0F are signal names.

The number of 1 to 18 indicates a terminal number.

## Input response time

Timing	Setting value											
	No Setting	20 $\mu$ s	50 $\mu$ s	0.1ms	0.2ms <sup>*1</sup>	0.4ms	0.6ms	1ms	5ms	10ms	20ms	70ms
OFF→ON (MAX)	5 $\mu$ s	20 $\mu$ s	50 $\mu$ s	0.1ms	0.2ms	0.4ms	0.6ms	1ms	5ms	10ms	20ms	70ms
ON→OFF (MAX)	10 $\mu$ s	25 $\mu$ s	50 $\mu$ s	0.1ms	0.2ms	0.4ms	0.6ms	1ms	5ms	10ms	20ms	70ms

\*1 The default value of input response time is 0.2ms.

## RX40NC6H DC high-speed input module

Item	Specifications	Appearance
Number of input points	16 points	
Rated input voltage	24VDC (ripple ratio: within 5%) (allowable voltage range: 20.4 to 28.8VDC)	
Rated input current	6.0mA TYP. (at 24VDC)	
ON voltage/ON current	15V or higher/4mA or higher	
OFF voltage/OFF current	8V or lower/1.7mA or lower	
Input resistance	3.9kΩ	
Response time	☞ Page 46 Input response time	
Withstand voltage	510VACrms, 1 minute	
Isolation resistance	10MΩ or higher by isolation resistance tester	
Noise immunity*1	Simulator noise 500Vp-p, noise width 1μs, noise frequency 25 to 60Hz (noise simulator condition)	
Protection degree	IP2X	
Wiring method for common	8 points/common (common terminal: TB9, TB18) Negative common type	
Number of occupied I/O points	16 points (I/O assignment: Input 16 points)	
Interrupt function	Available (can be set in the "Module Parameter")	
External interface	18-point screw terminal block (M3×6 screw) ☞ Page 104 18-point screw terminal block type module	
Internal current consumption (5VDC)	100mA (TYP. all points ON)	
Weight	0.16kg	

\*1 The noise immunity is the value for when the input response time setting is set to 50μs or longer.

### Derating chart

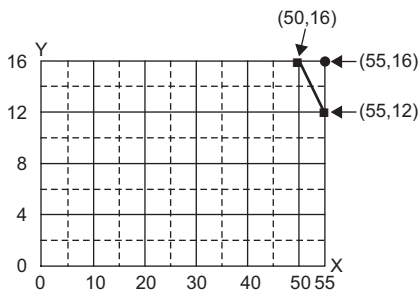

- : Input voltage 26.4VDC
- : Input voltage 28.8VDC
- X: Ambient temperature (°C)
- Y: Number of simultaneous on points (point)

### Circuit configuration

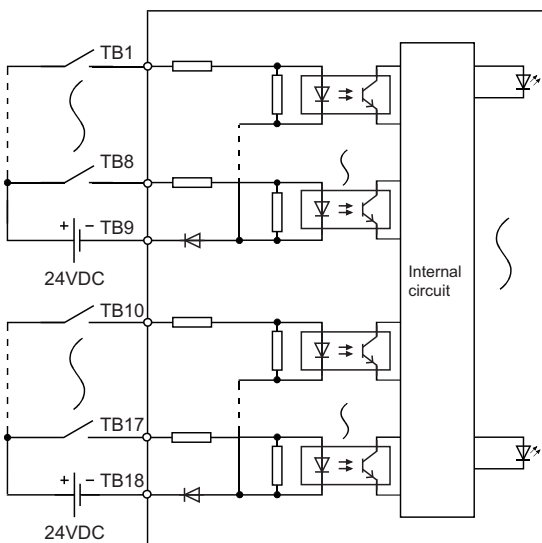

## Terminal connection

Connection diagram viewed from the front of the module

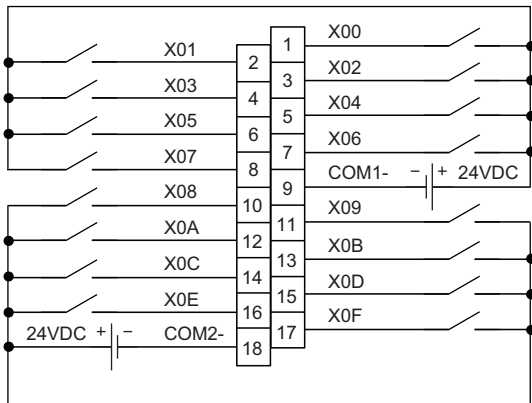

X00 to X0F are signal names.

The number of 1 to 18 indicates a terminal number.

## Input response time

Timing	Setting value											
	No Setting	20 $\mu$ s	50 $\mu$ s	0.1ms	0.2ms <sup>*1</sup>	0.4ms	0.6ms	1ms	5ms	10ms	20ms	70ms
OFF→ON (MAX)	5 $\mu$ s	20 $\mu$ s	50 $\mu$ s	0.1ms	0.2ms	0.4ms	0.6ms	1ms	5ms	10ms	20ms	70ms
ON→OFF (MAX)	10 $\mu$ s	25 $\mu$ s	50 $\mu$ s	0.1ms	0.2ms	0.4ms	0.6ms	1ms	5ms	10ms	20ms	70ms

\*1 The default value of input response time is 0.2ms.



## RX41C6HS DC high-speed input module

Item	Specifications	Appearance
Number of input points	32 points	
Rated input voltage	24VDC (ripple ratio: within 5%) (allowable voltage range: 20.4 to 28.8VDC)	
Rated input current	6.0mA TYP. (at 24VDC)	
ON voltage/ON current	19V or higher/4mA or higher	
OFF voltage/OFF current	6V or lower/1.7mA or lower	
Input resistance	4kΩ	
Response time	☞ Page 48 Input response time	
Withstand voltage	510VACrms, 1 minute	
Isolation resistance	10MΩ or higher by isolation resistance tester	
Noise immunity*1	Simulator noise 500Vp-p, noise width 1μs, noise frequency 25 to 60Hz (noise simulator condition)	
Protection degree	IP2X	
Wiring method for common	32 points/common (common terminal: B01, B02) Positive/negative common shared type	
Number of occupied I/O points	32 points (I/O assignment: Input 32 points)	
Interrupt function	Available (can be set in the "Module Parameter")	
External interface	40-pin connector ☞ Page 105 40-pin connector type module	
Internal current consumption (5VDC)	150mA (TYP. all points ON)	
Weight	0.12kg	

\*1 The noise immunity is the value for when the input response time setting is set to 50μs or longer.

### Derating chart

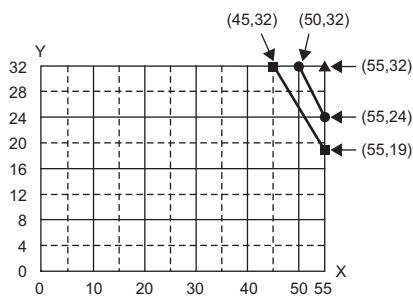

- ▲: Input voltage 24VDC
- : Input voltage 26.4VDC
- : Input voltage 28.8V
- X: Ambient temperature (°C)
- Y: Number of simultaneous on points (point)

### Circuit configuration

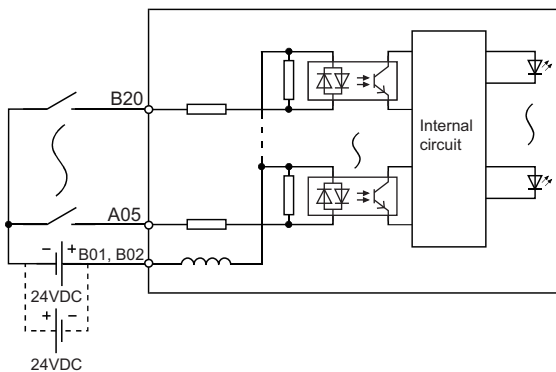

## Terminal connection

Connection diagram viewed from the front of the module

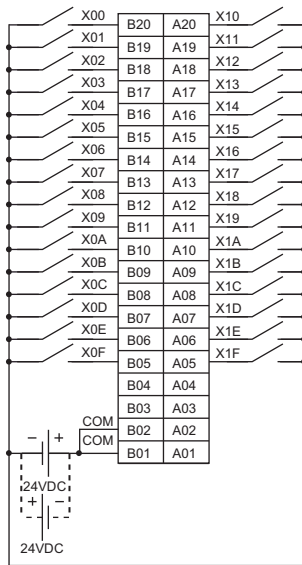

X00 to X1F are signal names.

A01 to A20 and B01 to B20 indicate pin numbers.

A01 to A04, B03, and B04 are empty.

## Input response time

Timing	Setting value												
	No Setting	10 $\mu$ s	20 $\mu$ s	50 $\mu$ s	0.1ms	0.2ms <sup>*1</sup>	0.4ms	0.6ms	1ms	5ms	10ms	20ms	70ms
OFF→ON (MAX)	1 $\mu$ s	10 $\mu$ s	20 $\mu$ s	50 $\mu$ s	0.1ms	0.2ms	0.4ms	0.6ms	1ms	5ms	10ms	20ms	70ms
ON→OFF (MAX)	1 $\mu$ s	10 $\mu$ s	20 $\mu$ s	50 $\mu$ s	0.1ms	0.2ms	0.4ms	0.6ms	1ms	5ms	10ms	20ms	70ms

\*1 The default value of input response time is 0.2ms.

## RX61C6HS DC high-speed input module

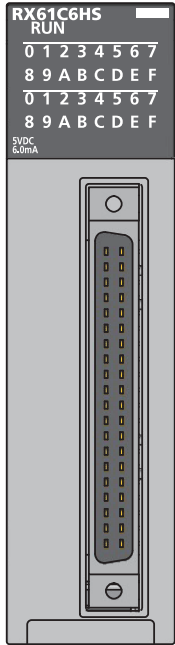
Item	Specifications	Appearance
Number of input points	32 points	
Rated input voltage	5VDC (ripple ratio: within 5%) (allowable voltage range: 4.25 to 6VDC)	
Rated input current	6.0mA TYP. (at 5VDC)	
ON voltage/ON current	3.5V or higher/3mA or higher	
OFF voltage/OFF current	1V or lower/1mA or lower	
Input resistance	600Ω	
Response time	☞ Page 50 Input response time	
Withstand voltage	510VACrms, 1 minute	
Isolation resistance	10MΩ or higher by isolation resistance tester	
Noise immunity*1	Simulator noise 500Vp-p, noise width 1μs, noise frequency 25 to 60Hz (noise simulator condition)	
Protection degree	IP2X	
Wiring method for common	32 points/common (common terminal: B01, B02) Positive/negative common shared type	
Number of occupied I/O points	32 points (I/O assignment: Input 32 points)	
Interrupt function	Available (can be set in the "Module Parameter")	
External interface	40-pin connector ☞ Page 105 40-pin connector type module	
Internal current consumption (5VDC)	150mA (TYP. all points ON)	
Weight	0.12kg	

\*1 The noise immunity is the value for when the input response time setting is set to 50μs or longer.

### ■ Circuit configuration

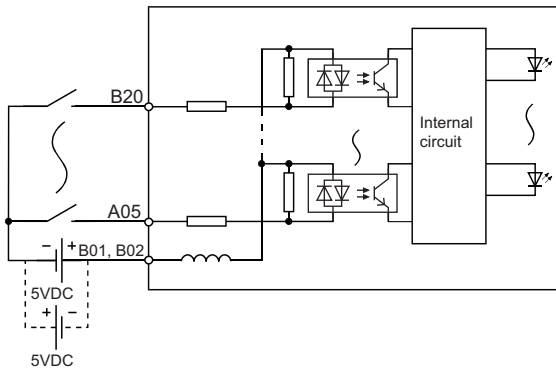

## Terminal connection

Connection diagram viewed from the front of the module

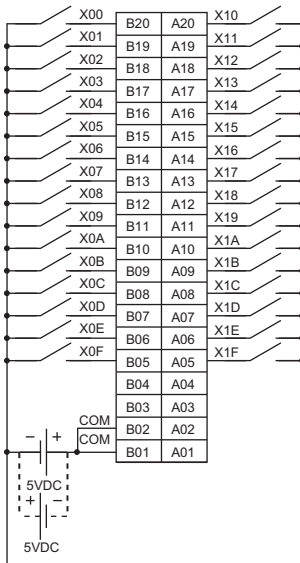

X00 to X1F are signal names.

A01 to A20 and B01 to B20 indicate pin numbers.

A01 to A04, B03, and B04 are empty.

## Input response time

Timing	Setting value												
	No Setting	10 $\mu$ s	20 $\mu$ s	50 $\mu$ s	0.1ms	0.2ms <sup>*1</sup>	0.4ms	0.6ms	1ms	5ms	10ms	20ms	70ms
OFF→ON (MAX)	1 $\mu$ s	10 $\mu$ s	20 $\mu$ s	50 $\mu$ s	0.1ms	0.2ms	0.4ms	0.6ms	1ms	5ms	10ms	20ms	70ms
ON→OFF (MAX)	1 $\mu$ s	10 $\mu$ s	20 $\mu$ s	50 $\mu$ s	0.1ms	0.2ms	0.4ms	0.6ms	1ms	5ms	10ms	20ms	70ms

\*1 The default value of input response time is 0.2ms.

# Output modules

The following output modules are equipped with the overload protection function and overheat protection function.

Applicable module models.....RY40NT5P, RY40NT5P-TS, RY41NT2P, RY41NT2P-TS, RY42NT2P, RY40PT5P, RY40PT5P-TS, RY41PT1P, RY41PT1P-TS, RY42PT1P

Function	Description
Overload protection* <sup>1</sup>	<ul style="list-style-type: none"> <li>• If an output module detects an overcurrent, current limiter operation*<sup>2</sup> is activated to limit the output current.</li> <li>• For the overcurrent detection value and limit current, check the "Overload protection" column of the specifications of each module.</li> <li>• If the load current falls below the overcurrent detection value, the normal operation resumes.</li> </ul>
Overheat protection* <sup>1</sup>	<ul style="list-style-type: none"> <li>• If an output module continues to output an overcurrent due to overload, heat is generated inside the module. If a high temperature heat is detected inside the module, the output turns off.</li> <li>• The number of output points where the overheat protection function can be used simultaneously varies at each module. Check the "Overheat protection" column of the specifications of each module.</li> <li>• If the heat drops, the normal operation resumes automatically.</li> </ul>

\*1 This function is intended to protect the internal circuit of a module, not to protect external devices. Additionally, an abnormal load can cause the module internal temperature to rise, resulting in deterioration of the output elements and discoloration of the case and printed-circuit board. In the event of an abnormal load, turn off the corresponding output immediately and eliminate the cause.

\*2 This operation limits an overcurrent to a certain current value, which allows a continuous output.

## RY10R2 contact output module

Item	Specifications	Appearance	
Number of output points	16 points		
Rated switching voltage/current	24VDC 2A (resistive load)/point, 8A/common 240VAC 2A (COS $\phi$ = 1)/point, 8A/common		
Minimum switching load	5VDC, 1mA		
Maximum switching load	264VAC 125VDC		
Response time	OFF→ON		10ms or less
	ON→OFF		12ms or less
Life	Mechanical		20 million times or more
	Electrical		☞ Page 97 Relay life (contact switching life)
Maximum switching frequency	3600 times/hour		
Surge suppressor	None		
Fuse	None		
Withstand voltage	2300VACrms, 1 minute		
Isolation resistance	10M $\Omega$ or higher by isolation resistance tester		
Noise immunity	Simulator noise 1500Vp-p, noise width 1 $\mu$ s, noise frequency 25 to 60Hz (noise simulator condition)		
Protection degree	IP1X		
Wiring method for common	16 points/common (common terminal: TB17)		
Number of occupied I/O points	16 points (I/O assignment: Output 16 points)		
External interface	18-point screw terminal block (M3 $\times$ 6 screw) ☞ Page 104 18-point screw terminal block type module		
Internal current consumption (5VDC)	450mA (TYP. all points ON)		
Weight	0.22kg		

### ■ Circuit configuration

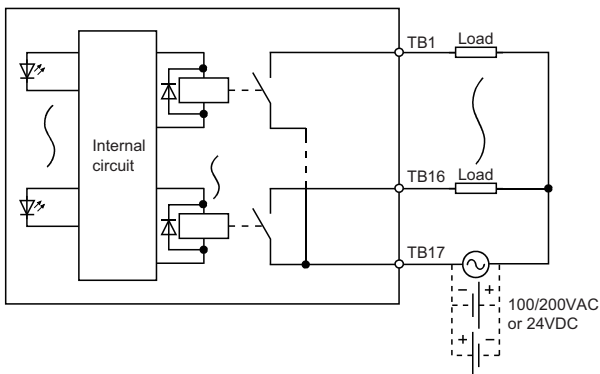

## Terminal connection

Connection diagram viewed from the front of the module

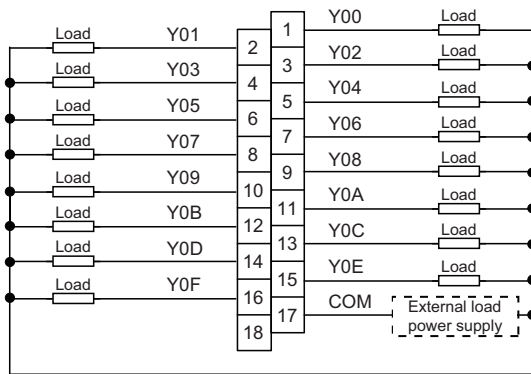

Y00 to Y0F are signal names.

The number of 1 to 18 indicates a terminal number.

The terminal number 18 is empty.

- The figure below shows the external power supply.

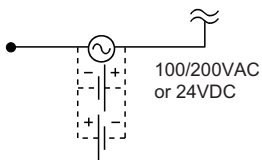

## RY10R2-TS contact output module

Item	Specifications	Appearance	
Number of output points	16 points		
Rated switching voltage/current	24VDC 2A (resistive load)/point, 8A/common 240VAC 2A (COS $\phi$ = 1)/point, 8A/common		
Minimum switching load	5VDC, 1mA		
Maximum switching load	264VAC 125VDC		
Response time	OFF→ON		10ms or less
	ON→OFF		12ms or less
Life	Mechanical		20 million times or more
	Electrical		☞ Page 97 Relay life (contact switching life)
Maximum switching frequency	3600 times/hour		
Surge suppressor	None		
Fuse	None		
Withstand voltage	2300VACrms, 1 minute		
Isolation resistance	10M $\Omega$ or higher by isolation resistance tester		
Noise immunity	Simulator noise 1500Vp-p, noise width 1 $\mu$ s, noise frequency 25 to 60Hz (noise simulator condition)		
Protection degree	IP1X		
Wiring method for common	16 points/common (common terminal: 9)		
Number of occupied I/O points	16 points (I/O assignment: Output 16 points)		
External interface	Two-piece spring clamp terminal block ☞ Page 105 40-pin connector type module		
Internal current consumption (5VDC)	450mA (TYP. all points ON)		
Weight	0.19kg		

### ■ Circuit configuration

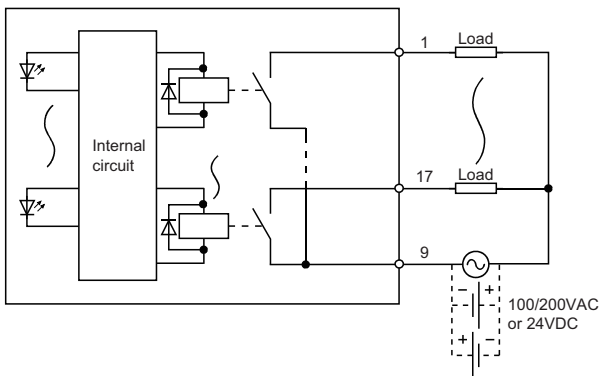



## Terminal connection

Connection diagram viewed from the front of the module

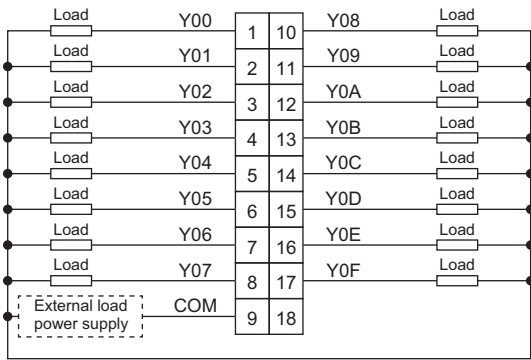

Y00 to Y0F are signal names.

The number of 1 to 18 indicates a terminal number.

The terminal number 18 is empty.

- The figure below shows the external power supply.

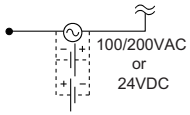

## RY18R2A contact output module (all points independent contact)

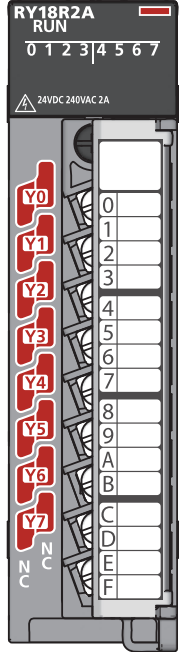
Item	Specifications	Appearance	
Number of output points	8 points		
Rated switching voltage/current	24VDC 2A (resistive load)/point, 8A/module 240VAC 2A (COS $\phi$ = 1)/point, 8A/module		
Minimum switching load	5VDC, 1mA		
Maximum switching load	264VAC 125VDC		
Response time	OFF→ON		10ms or less
	ON→OFF		12ms or less
Life	Mechanical		20 million times or more
	Electrical		☞ Page 97 Relay life (contact switching life)
Maximum switching frequency	3600 times/hour		
Surge suppressor	None		
Fuse	None		
Withstand voltage	2300VACrms, 1 minute		
Isolation resistance	10M $\Omega$ or higher by isolation resistance tester		
Noise immunity	Simulator noise 1500Vp-p, noise width 1 $\mu$ s, noise frequency 25 to 60Hz (noise simulator condition)		
Protection degree	IP1X		
Wiring method for common	No common (all points independent contact)		
Number of occupied I/O points	16 points (I/O assignment: Output 16 points)		
External interface	18-point screw terminal block (M3 $\times$ 6 screw) ☞ Page 104 18-point screw terminal block type module		
Internal current consumption (5VDC)	260mA (TYP. all points ON)		
Weight	0.19kg		

### ■ Circuit configuration

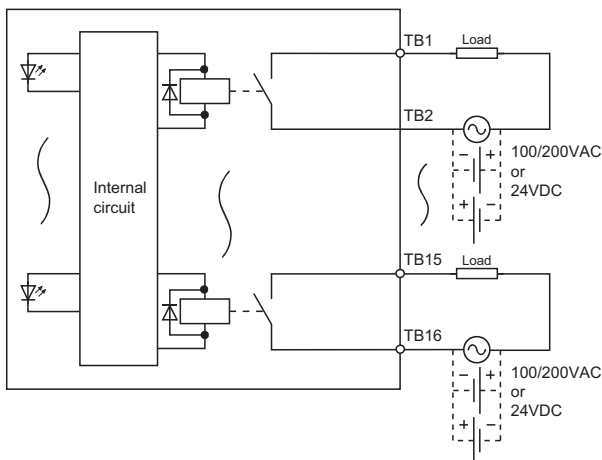

## Terminal connection

Connection diagram viewed from the front of the module

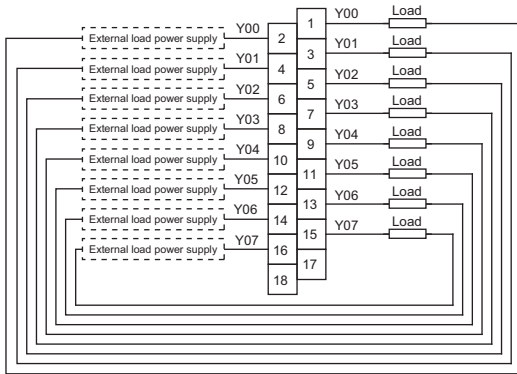

Y00 to Y07 are signal names.

The number of 1 to 18 indicates a terminal number.

The terminal number 17 and 18 are empty.

- The figure below shows the external power supply.

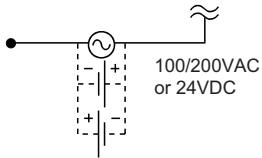

## RY20S6 triac output module

Item	Specifications	Appearance				
Number of output points	16 points					
Rated load voltage, frequency	100 to 240VAC (+10%/-15%), 50/60Hz (±3Hz)					
Maximum load current	0.6A/point, 4.8A/common					
Load voltage distortion ratio	Within 5%					
Maximum load voltage	264VAC					
Minimum load voltage/current	24VAC/100mA, 100VAC/25mA, 240VAC/25mA					
Maximum inrush current	20A/cycle or lower					
Leakage current at OFF	3mA or lower (at 240V, 60Hz), 1.5mA or lower (at 120V, 60Hz)					
Maximum voltage drop at ON	1.5V or lower (at load current of 0.6A)					
Response time	<table border="1"> <tr> <td>OFF→ON</td> <td>Total of 1ms and 0.5 cycles or less</td> </tr> <tr> <td>ON→OFF</td> <td>Total of 1ms and 0.5 cycles or less (rated load, resistive load)</td> </tr> </table>		OFF→ON	Total of 1ms and 0.5 cycles or less	ON→OFF	Total of 1ms and 0.5 cycles or less (rated load, resistive load)
OFF→ON	Total of 1ms and 0.5 cycles or less					
ON→OFF	Total of 1ms and 0.5 cycles or less (rated load, resistive load)					
Surge suppressor	CR absorber					
Fuse	None (Attaching a fuse to each external wiring is recommended.)					
Withstand voltage	2300VACrms, 1 minute					
Isolation resistance	10MΩ or higher by isolation resistance tester					
Noise immunity	Simulator noise 1500Vp-p, noise width 1μs, noise frequency 25 to 60Hz (noise simulator condition)					
Protection degree	IP1X					
Wiring method for common	16 points/common (common terminal: TB17)					
Number of occupied I/O points	16 points (I/O assignment: Output 16 points)					
External interface	18-point screw terminal block (M3×6 screw) <small>☞ Page 104 18-point screw terminal block type module</small>					
Internal current consumption (5VDC)	280mA (TYP. all points ON)					
Weight	0.24kg					

### ■Circuit configuration

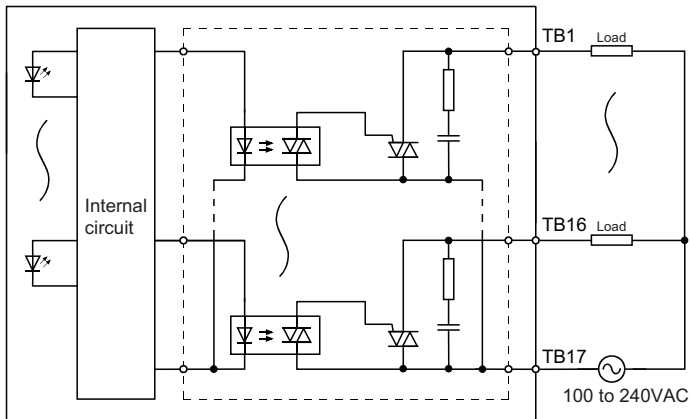

## Terminal connection

Connection diagram viewed from the front of the module

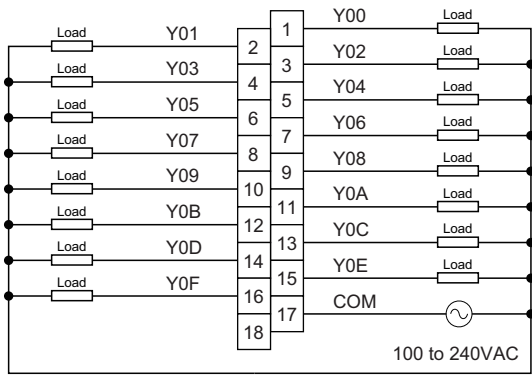

Y00 to Y0F are signal names.

The number of 1 to 18 indicates a terminal number.

The terminal number 18 is empty.

## RY40NT5P transistor output module

Item		Specifications	Appearance
Number of output points		16 points	
Rated load voltage		12/24VDC (allowable voltage range: 10.2 to 28.8VDC)	
Maximum load current		0.5A/point, Pilot Duty, 5A/common	
Maximum inrush current		Current is to be limited by the overload protection function.	
Leakage current at OFF		0.1mA or lower	
Maximum voltage drop at ON		0.2VDC (TYP.) 0.5A, 0.3VDC (MAX.) 0.5A	
Response time	OFF→ON	0.5ms or less	
	ON→OFF	1ms or less (rated load, resistive load)	
Surge suppressor		Zener diode	
Fuse		None	
External power supply	Voltage	12/24VDC (ripple ratio: within 5%) (allowable voltage range: 10.2 to 28.8VDC)	
	Current	4mA (at 24VDC)	
Withstand voltage		510VACrms, 1 minute	
Isolation resistance		10MΩ or higher by isolation resistance tester	
Noise immunity		Simulator noise 500Vp-p, noise width 1μs, noise frequency 25 to 60Hz (noise simulator condition)	
Protection degree		IP2X	
Wiring method for common		16 points/common (common terminal: TB18) Sink type	
Number of occupied I/O points		16 points (I/O assignment: Output 16 points)	
Protection functions	Overload protection	Limited current when detecting overcurrent: 1.5 to 3.5A/point Activated to each point. (☞ Page 51 Output modules)	
	Overheat protection	Activated to each point. (☞ Page 51 Output modules)	
External interface		18-point screw terminal block (M3×6 screw) ☞ Page 104 18-point screw terminal block type module	
Internal current consumption (5VDC)		140mA (TYP. all points ON)	
Weight		0.16kg	

### ■ Circuit configuration

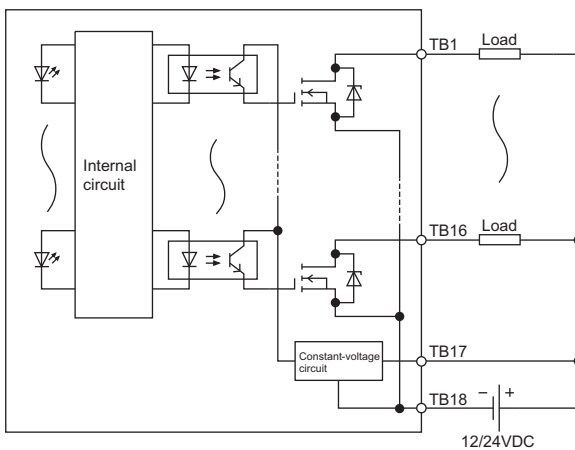

## Terminal connection

Connection diagram viewed from the front of the module

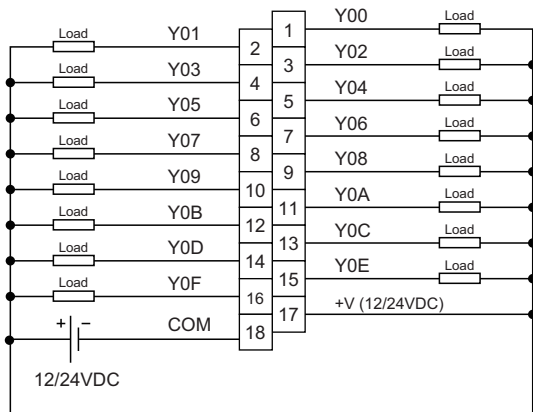

Y00 to Y0F are signal names.

The number of 1 to 18 indicates a terminal number.

## RY40NT5P-TS transistor output module

Item		Specifications	Appearance
Number of output points		16 points	
Rated load voltage		12/24VDC (allowable voltage range: 10.2 to 28.8VDC)	
Maximum load current		0.5A/point, Pilot Duty, 5A/common	
Maximum inrush current		Current is to be limited by the overload protection function.	
Leakage current at OFF		0.1mA or lower	
Maximum voltage drop at ON		0.2VDC (TYP.) 0.5A, 0.3VDC (MAX.) 0.5A	
Response time	OFF→ON	0.5ms or less	
	ON→OFF	1ms or less (rated load, resistive load)	
Surge suppressor		Zener diode	
Fuse		None	
External power supply	Voltage	12/24VDC (ripple ratio: within 5%) (allowable voltage range: 10.2 to 28.8VDC)	
	Current	6mA (at 24VDC)	
Withstand voltage		510VACrms, 1 minute	
Isolation resistance		10MΩ or higher by isolation resistance tester	
Noise immunity		Simulator noise 500Vp-p, noise width 1μs, noise frequency 25 to 60Hz (noise simulator condition)	
Protection degree		IP2X	
Wiring method for common		16 points/common (common terminal: 18) Sink type	
Number of occupied I/O points		16 points (I/O assignment: Output 16 points)	
Protection functions	Overload protection	Limited current when detecting overcurrent: 1.5 to 3.5A/point Activated to each point. (☞ Page 51 Output modules)	
	Overheat protection	Activated to each point. (☞ Page 51 Output modules)	
External interface		Two-piece spring clamp terminal block ☞ Page 105 40-pin connector type module	
Internal current consumption (5VDC)		140mA (TYP. all points ON)	
Weight		0.12kg	

### ■ Circuit configuration

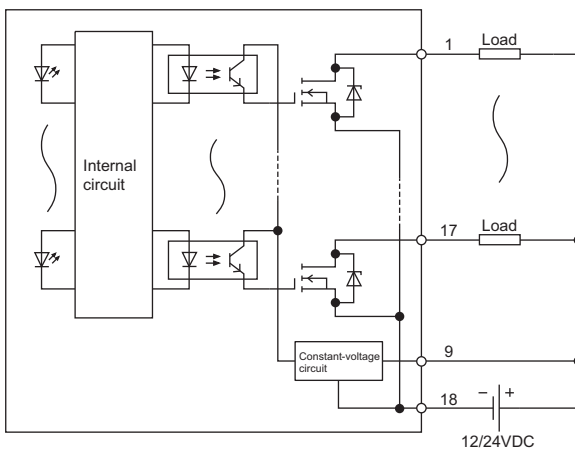



## Terminal connection

Connection diagram viewed from the front of the module

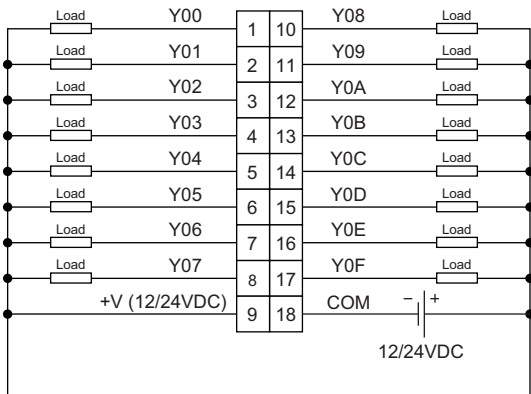

Y00 to Y0F are signal names.

The number of 1 to 18 indicates a terminal number.

## RY41NT2P transistor output module

Item		Specifications	Appearance
Number of output points		32 points	
Rated load voltage		12/24VDC (allowable voltage range: 10.2 to 28.8VDC)	
Maximum load current		0.2A/point, Pilot Duty, 2A/common	
Maximum inrush current		Current is to be limited by the overload protection function.	
Leakage current at OFF		0.1mA or lower	
Maximum voltage drop at ON		0.2VDC (TYP.) 0.2A, 0.3VDC (MAX.) 0.2A	
Response time	OFF→ON	0.5ms or less	
	ON→OFF	1ms or less (rated load, resistive load)	
Surge suppressor		Zener diode	
Fuse		None	
External power supply	Voltage	12/24VDC (ripple ratio: within 5%) (allowable voltage range: 10.2 to 28.8VDC)	
	Current	16mA (at 24VDC)	
Withstand voltage		510VACrms, 1 minute	
Isolation resistance		10MΩ or higher by isolation resistance tester	
Noise immunity		Simulator noise 500Vp-p, noise width 1μs, noise frequency 25 to 60Hz (noise simulator condition)	
Protection degree		IP2X	
Wiring method for common		32 points/common (common terminal: A01, A02) Sink type	
Number of occupied I/O points		32 points (I/O assignment: Output 32 points)	
Protection functions	Overload protection	Limited current when detecting overcurrent: 1.5 to 3A/point Activated to each point. ( Page 51 Output modules)	
	Overheat protection	Activated to each point. ( Page 51 Output modules)	
External interface		40-pin connector Page 105 40-pin connector type module	
Internal current consumption (5VDC)		180mA (TYP. all points ON)	
Weight		0.11kg	

### ■Circuit configuration

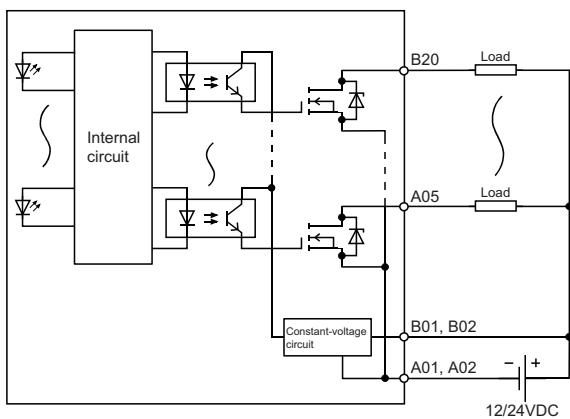

## Terminal connection

Connection diagram viewed from the front of the module

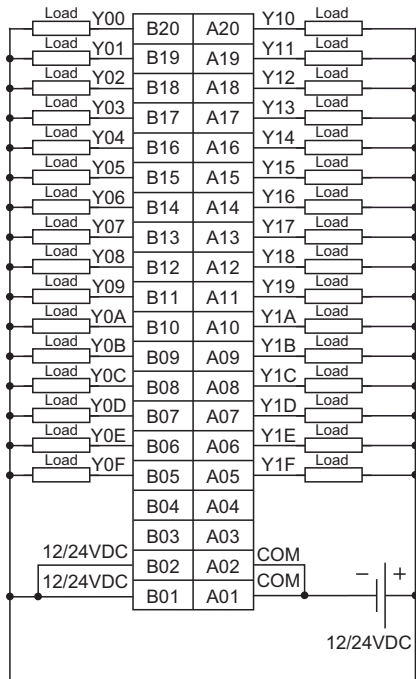

Y00 to Y1F are signal names.

A01 to A20 and B01 to B20 indicate pin numbers.

A03, A04, B03, and B04 are empty.

## RY41NT2P-TS transistor output module

Item		Specifications	Appearance
Number of output points		32 points	
Rated load voltage		12/24VDC (allowable voltage range: 10.2 to 28.8VDC)	
Maximum load current		0.2A/point, Pilot Duty, 2A/common	
Maximum inrush current		Current is to be limited by the overload protection function.	
Leakage current at OFF		0.1mA or lower	
Maximum voltage drop at ON		0.2VDC (TYP.) 0.2A, 0.3VDC (MAX.) 0.2A	
Response time	OFF→ON	0.5ms or less	
	ON→OFF	1ms or less (rated load, resistive load)	
Surge suppressor		Zener diode	
Fuse		None	
External power supply	Voltage	12/24VDC (ripple ratio: within 5%) (allowable voltage range: 10.2 to 28.8VDC)	
	Current	17mA (at 24VDC)	
Withstand voltage		510VACrms, 1 minute	
Isolation resistance		10MΩ or higher by isolation resistance tester	
Noise immunity		Simulator noise 500Vp-p, noise width 1μs, noise frequency 25 to 60Hz (noise simulator condition)	
Protection degree		IP2X	
Wiring method for common		32 points/common (common terminal: 34) Sink type	
Number of occupied I/O points		32 points (I/O assignment: Output 32 points)	
Protection functions	Overload protection	Limited current when detecting overcurrent: 1.5 to 3A/point Activated to each point. (☞ Page 51 Output modules)	
	Overheat protection	Activated to each point. (☞ Page 51 Output modules)	
External interface		Two-piece spring clamp terminal block ☞ Page 106 Spring clamp terminal block (lever type)	
Internal current consumption (5VDC)		180mA (TYP. all points ON)	
Weight		0.13kg	

### ■ Circuit configuration

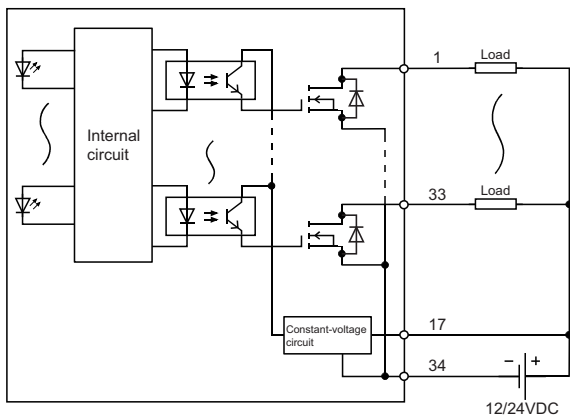

## Terminal connection

Connection diagram viewed from the front of the module

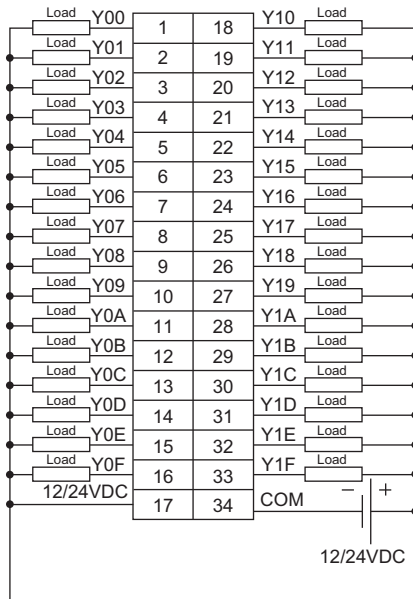

Y00 to Y1F are signal names.

The number of 1 to 34 indicates a pin number.

## RY41NT2H transistor high-speed output module

Item	Specifications	Appearance	
Number of output points	32 points		
Rated load voltage	5/12/24VDC (allowable voltage range: 4.25 to 28.8VDC)		
Maximum load current	0.2A/point, 2A/common		
Maximum inrush current	0.7A, 10ms or less		
Leakage current at OFF	0.1mA or lower		
Maximum voltage drop at ON	0.1VDC (TYP.) 0.2A, 0.2VDC (MAX.) 0.2A		
Response time	OFF→ON		1μs or less
	ON→OFF		2μs or less (rated load, resistive load)
Surge suppressor	Zener diode		
Fuse	None		
Withstand voltage	510VACrms, 1 minute		
Isolation resistance	10MΩ or higher by isolation resistance tester		
Noise immunity	Simulator noise 500Vp-p, noise width 1μs, noise frequency 25 to 60Hz (noise simulator condition)		
Protection degree	IP2X		
Wiring method for common	32 points/common (common terminal: A01, A02) Sink type		
Number of occupied I/O points	32 points (I/O assignment: Output 32 points)		
Protection functions	None		
External interface	40-pin connector Page 105 40-pin connector type module		
Internal current consumption (5VDC)	420mA (TYP. all points ON)		
Weight	0.12kg		

### ■ Circuit configuration

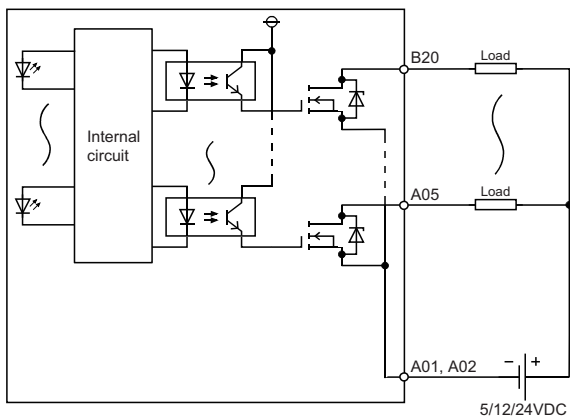

## Terminal connection

Connection diagram viewed from the front of the module

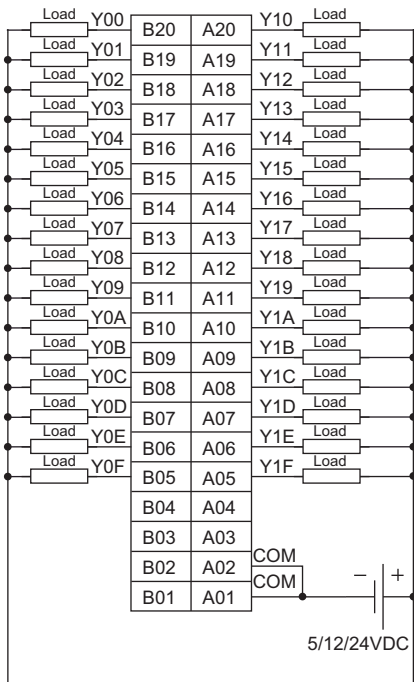

Y00 to Y1F are signal names.

A01 to A20 and B01 to B20 indicate pin numbers.

A03, A04, and B01 to B04 are empty.

## RY42NT2P transistor output module

Item		Specifications	Appearance
Number of output points		64 points	
Rated load voltage		12/24VDC (allowable voltage range: 10.2 to 28.8VDC)	
Maximum load current		0.2A/point, Pilot Duty, 2A/common	
Maximum inrush current		Current is to be limited by the overload protection function.	
Leakage current at OFF		0.1mA or lower	
Maximum voltage drop at ON		0.2VDC (TYP.) 0.2A, 0.3VDC (MAX.) 0.2A	
Response time	OFF→ON	0.5ms or less	
	ON→OFF	1ms or less (rated load, resistive load)	
Surge suppressor		Zener diode	
Fuse		None	
External power supply	Voltage	12/24VDC (ripple ratio: within 5%) (allowable voltage range: 10.2 to 28.8VDC)	
	Current	16mA (at 24VDC)/common	
Withstand voltage		510VACrms, 1 minute	
Isolation resistance		10MΩ or higher by isolation resistance tester	
Noise immunity		Simulator noise 500Vp-p, noise width 1μs, noise frequency 25 to 60Hz (noise simulator condition)	
Protection degree		IP2X	
Wiring method for common		32 points/common (common terminal: 1A01, 1A02, 2A01, 2A02) Sink type	
Number of occupied I/O points		64 points (I/O assignment: Output 64 points)	
Protection functions	Overload protection	Limited current when detecting overcurrent: 1.5 to 3A/point Activated to each point. (☞ Page 51 Output modules)	
	Overheat protection	Activated to each point. (☞ Page 51 Output modules)	
External interface		40-pin connector ☞ Page 105 40-pin connector type module	
Internal current consumption (5VDC)		250mA (TYP. all points ON)	
Weight		0.13kg	

### ■ Circuit configuration

The figure below shows the case of 32 points in the first half (F). The case of 32 points in the latter half (L) is the same.

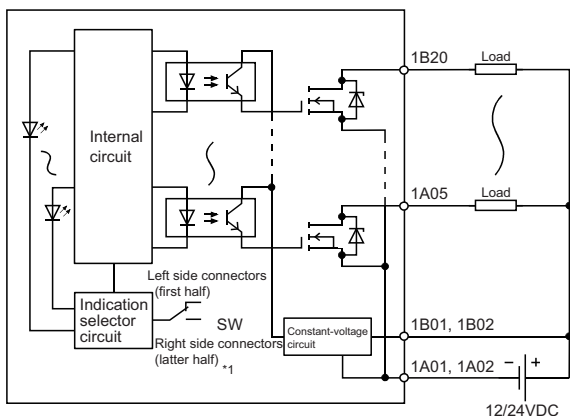

\*1 The LED indicates the first half (Y00 to Y1F) by turning the switch to the left (F), while the LED indicates the latter half (Y20 to Y3F) by turning the switch to the right (L).



## Terminal connection

Connection diagram viewed from the front of the module

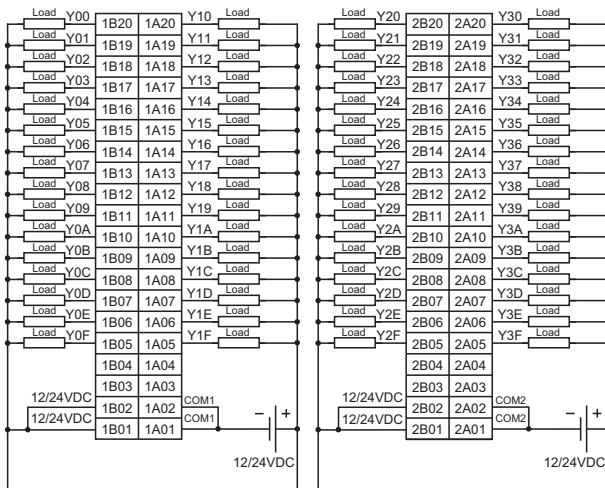

Y00 to Y1F and Y20 to Y3F are signal names.

1A01 to 1A20, 1B01 to 1B20, 2A01 to 2A20, and 2B01 to 2B20 indicate pin numbers.

1A03, 1A04, 1B03, 1B04, 2A03, 2A04, 2B03, and 2B04 are empty.

## RY40PT5P transistor output module

Item		Specifications	Appearance
Number of output points		16 points	
Rated load voltage		12/24VDC (allowable voltage range: 10.2 to 28.8VDC)	
Maximum load current		0.5A/point, Pilot Duty, 5A/common	
Maximum inrush current		Current is to be limited by the overload protection function.	
Leakage current at OFF		0.1mA or lower	
Maximum voltage drop at ON		0.2VDC (TYP.) 0.5A, 0.3VDC (MAX.) 0.5A	
Response time	OFF→ON	0.5ms or less	
	ON→OFF	1ms or less (rated load, resistive load)	
Surge suppressor		Zener diode	
Fuse		None	
External power supply	Voltage	12/24VDC (ripple ratio: within 5%) (allowable voltage range: 10.2 to 28.8VDC)	
	Current	16mA (at 24VDC)	
Withstand voltage		510VACrms, 1 minute	
Isolation resistance		10MΩ or higher by isolation resistance tester	
Noise immunity		Simulator noise 500Vp-p, noise width 1μs, noise frequency 25 to 60Hz (noise simulator condition)	
Protection degree		IP2X	
Wiring method for common		16 points/common (common terminal: TB17) Source type	
Number of occupied I/O points		16 points (I/O assignment: Output 16 points)	
Protection functions	Overload protection	Overcurrent detection: 1.5A or higher/point Activated to each point. (☞ Page 51 Output modules)	
	Overheat protection	Activated to each point. (☞ Page 51 Output modules)	
External interface		18-point screw terminal block (M3×6 screw) ☞ Page 104 18-point screw terminal block type module	
Internal current consumption (5VDC)		130mA (TYP. all points ON)	
Weight		0.16kg	

### ■ Circuit configuration

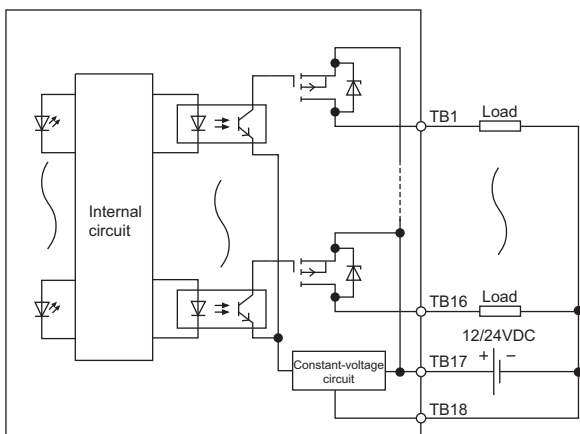

## Terminal connection

Connection diagram viewed from the front of the module

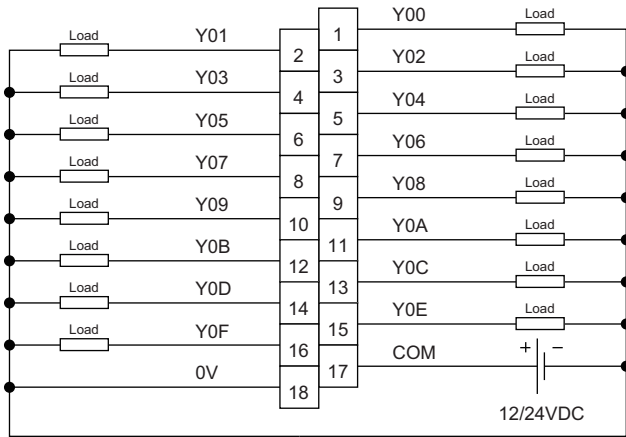

Y00 to Y0F are signal names.

The number of 1 to 18 indicates a terminal number.

## RY40PT5P-TS transistor output module

Item		Specifications	Appearance
Number of output points		16 points	
Rated load voltage		12/24VDC (allowable voltage range: 10.2 to 28.8VDC)	
Maximum load current		0.5A/point, Pilot Duty, 5A/common	
Maximum inrush current		Current is to be limited by the overload protection function.	
Leakage current at OFF		0.1mA or lower	
Maximum voltage drop at ON		0.2VDC (TYP.) 0.5A, 0.3VDC (MAX.) 0.5A	
Response time	OFF→ON	0.5ms or less	
	ON→OFF	1ms or less (rated load, resistive load)	
Surge suppressor		Zener diode	
Fuse		None	
External power supply	Voltage	12/24VDC (ripple ratio: within 5%) (allowable voltage range: 10.2 to 28.8VDC)	
	Current	20mA (at 24VDC)	
Withstand voltage		510VACrms, 1 minute	
Isolation resistance		10MΩ or higher by isolation resistance tester	
Noise immunity		Simulator noise 500Vp-p, noise width 1μs, noise frequency 25 to 60Hz (noise simulator condition)	
Protection degree		IP2X	
Wiring method for common		16 points/common (common terminal: 9) Source type	
Number of occupied I/O points		16 points (I/O assignment: Output 16 points)	
Protection functions	Overload protection	Overcurrent detection: 1.0A or higher/point Activated to each point. ( Page 51 Output modules)	
	Overheat protection	Activated to each point. ( Page 51 Output modules)	
External interface		Two-piece spring clamp terminal block Page 106 Spring clamp terminal block (lever type)	
Internal current consumption (5VDC)		130mA	
Weight		0.12kg	

### ■ Circuit configuration

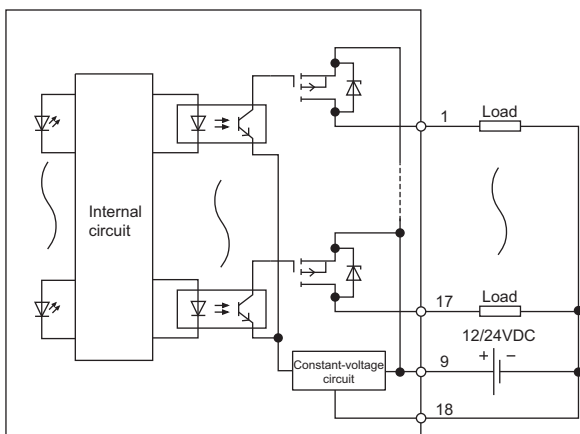

## Terminal connection

Connection diagram viewed from the front of the module

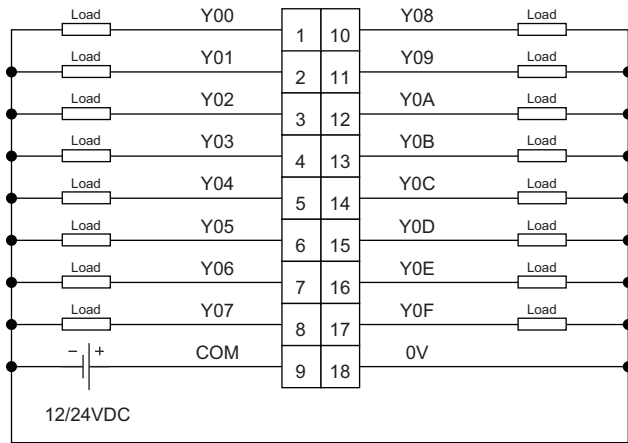

Y00 to Y0F are signal names.

The number of 1 to 18 indicates a terminal number.

## RY41PT1P transistor output module

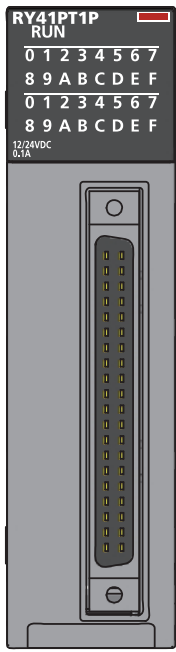
Item		Specifications	Appearance
Number of output points		32 points	
Rated load voltage		12/24VDC (allowable voltage range: 10.2 to 28.8VDC)	
Maximum load current		0.1A/point, Pilot Duty, 2A/common	
Maximum inrush current		Current is to be limited by the overload protection function.	
Leakage current at OFF		0.1mA or lower	
Maximum voltage drop at ON		0.1VDC (TYP.) 0.1A, 0.2VDC (MAX.) 0.1A	
Response time	OFF→ON	0.5ms or less	
	ON→OFF	1ms or less (rated load, resistive load)	
Surge suppressor		Zener diode	
Fuse		None	
External power supply	Voltage	12/24VDC (ripple ratio: within 5%) (allowable voltage range: 10.2 to 28.8VDC)	
	Current	19mA (at 24VDC)	
Withstand voltage		510VACrms, 1 minute	
Isolation resistance		10MΩ or higher by isolation resistance tester	
Noise immunity		Simulator noise 500Vp-p, noise width 1μs, noise frequency 25 to 60Hz (noise simulator condition)	
Protection degree		IP2X	
Wiring method for common		32 points/common (common terminal: B01, B02) Source type	
Number of occupied I/O points		32 points (I/O assignment: Output 32 points)	
Protection functions	Overload protection	Limited current when detecting overcurrent: 1 to 3A/point (Activated to each point. (Page 51 Output modules))	
	Overheat protection	Activated in increments of 2 points. (Page 51 Output modules)	
External interface		40-pin connector Page 105 40-pin connector type module	
Internal current consumption (5VDC)		190mA (TYP. all points ON)	
Weight		0.11kg	

### ■ Circuit configuration

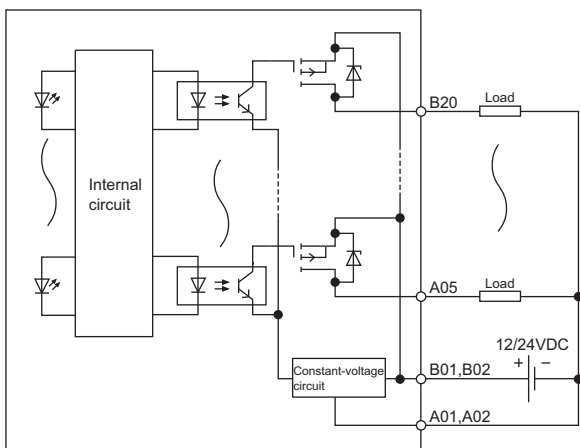

## Terminal connection

Connection diagram viewed from the front of the module

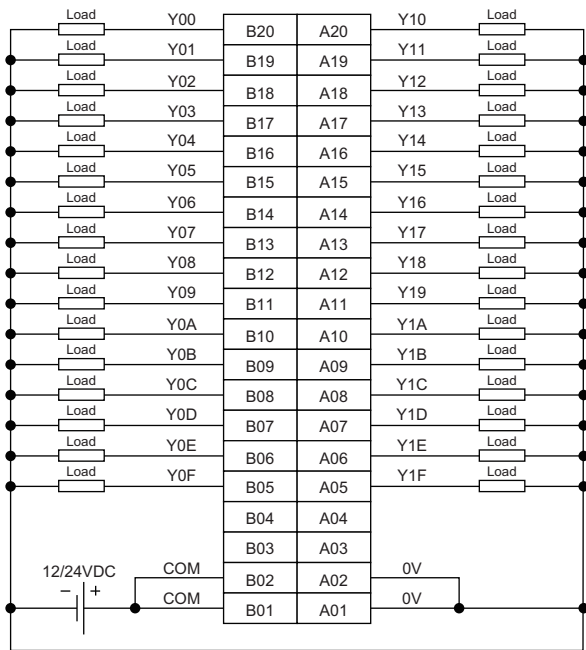

Y00 to Y1F are signal names.

A01 to A20 and B01 to B20 indicate pin numbers.

A03, A04, B03, and B04 are empty.

## RY41PT1P-TS transistor output module

Item		Specifications	Appearance
Number of output points		32 points	
Rated load voltage		12/24VDC (allowable voltage range: 10.2 to 28.8VDC)	
Maximum load current		0.1A/point, Pilot Duty, 2A/common	
Maximum inrush current		Current is to be limited by the overload protection function.	
Leakage current at OFF		0.1mA or lower	
Maximum voltage drop at ON		0.1VDC (TYP.) 0.1A, 0.2VDC (MAX.) 0.1A	
Response time	OFF→ON	0.5ms or less	
	ON→OFF	1ms or less (rated load, resistive load)	
Surge suppressor		Zener diode	
Fuse		None	
External power supply	Voltage	12/24VDC (ripple ratio: within 5%) (allowable voltage range: 10.2 to 28.8VDC)	
	Current	19mA (at 24VDC)	
Withstand voltage		510VACrms, 1 minute	
Isolation resistance		10MΩ or higher by isolation resistance tester	
Noise immunity		Simulator noise 500Vp-p, noise width 1μs, noise frequency 25 to 60Hz (noise simulator condition)	
Protection degree		IP2X	
Wiring method for common		32 points/common (common terminal: 17) Source type	
Number of occupied I/O points		32 points (I/O assignment: Output 32 points)	
Protection functions	Overload protection	Limited current when detecting overcurrent: 1 to 3A/point Activated to each point. (☞ Page 51 Output modules)	
	Overheat protection	Activated in increments of 2 points. (☞ Page 51 Output modules)	
External interface		Two-piece spring clamp terminal block ☞ Page 105 40-pin connector type module	
Internal current consumption (5VDC)		190mA (TYP. all points ON)	
Weight		0.13kg	

### ■ Circuit configuration

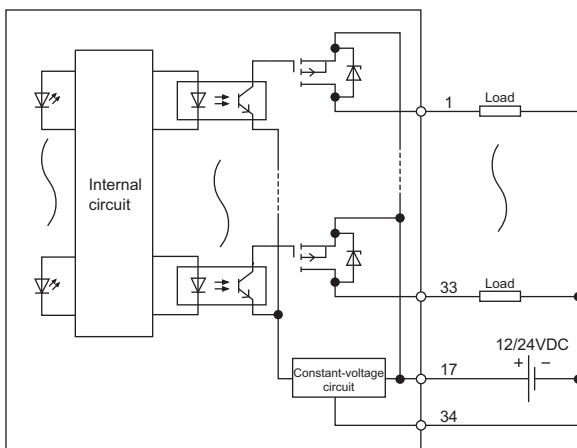



## Terminal connection

Connection diagram viewed from the front of the module

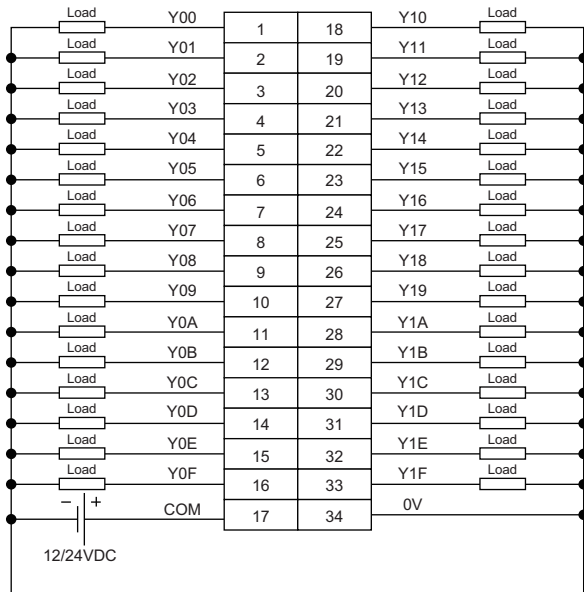

Y00 to Y1F are signal names.

The number of 1 to 34 indicates a pin number.

## RY41PT2H transistor high-speed output module

Item	Specifications	Appearance	
Number of output points	32 points		
Rated load voltage	5/12/24VDC (allowable voltage range: 4.25 to 28.8VDC)		
Maximum load current	0.2A/point, 2A/common		
Maximum inrush current	0.7A, 10ms or less		
Leakage current at OFF	0.1mA or lower		
Maximum voltage drop at ON	0.1VDC (TYP.) 0.2A, 0.2VDC (MAX.) 0.2A		
Response time	OFF→ON		1μs or less
	ON→OFF		2μs or less (rated load, resistive load)
Surge suppressor	Zener diode		
Fuse	None		
Withstand voltage	510VACrms, 1 minute		
Isolation resistance	10MΩ or higher by isolation resistance tester		
Noise immunity	Simulator noise 500Vp-p, noise width 1μs, noise frequency 25 to 60Hz (noise simulator condition)		
Protection degree	IP2X		
Wiring method for common	32 points/common (common terminal: B01, B02) Source type		
Number of occupied I/O points	32 points (I/O assignment: Output 32 points)		
Protection functions	None		
External interface	40-pin connector ☞ Page 105 40-pin connector type module		
Internal current consumption (5VDC)	410mA (TYP. all points ON)		
Weight	0.12kg		

### ■ Circuit configuration

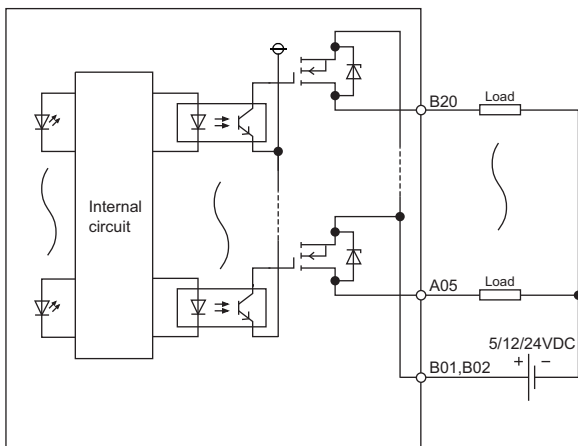

## Terminal connection

Connection diagram viewed from the front of the module

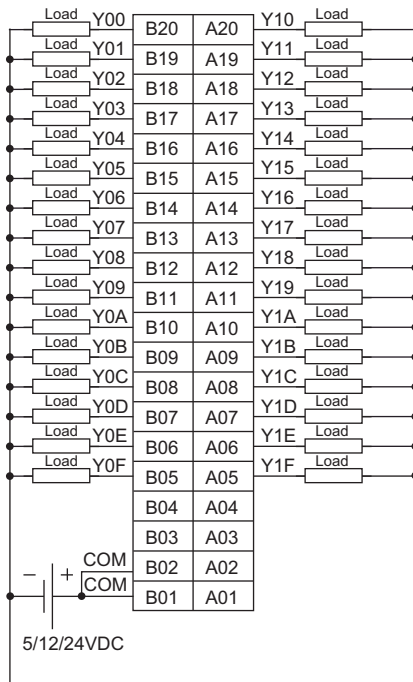

Y00 to Y1F are signal names.

A01 to A20 and B01 to B20 indicate pin numbers.

A01 to A04, B03, and B04 are empty.

## RY42PT1P transistor output module

Item		Specifications	Appearance
Number of output points		64 points	
Rated load voltage		12/24VDC (allowable voltage range: 10.2 to 28.8VDC)	
Maximum load current		0.1A/point, Pilot Duty, 2A/common	
Maximum inrush current		Current is to be limited by the overload protection function.	
Leakage current at OFF		0.1mA or lower	
Maximum voltage drop at ON		0.1VDC (TYP.) 0.1A, 0.2VDC (MAX.) 0.1A	
Response time	OFF→ON	0.5ms or less	
	ON→OFF	1ms or less (rated load, resistive load)	
Surge suppressor		Zener diode	
Fuse		None	
External power supply	Voltage	12/24VDC (ripple ratio: within 5%) (allowable voltage range: 10.2 to 28.8VDC)	
	Current	19mA (at 24VDC)/common	
Withstand voltage		510VACrms, 1 minute	
Isolation resistance		10MΩ or higher by isolation resistance tester	
Noise immunity		Simulator noise 500Vp-p, noise width 1μs, noise frequency 25 to 60Hz (noise simulator condition)	
Protection degree		IP2X	
Wiring method for common		32 points/common (common terminal: 1B01, 1B02, 2B01, 2B02) Source type	
Number of occupied I/O points		64 points (I/O assignment: Output 64 points)	
Protection functions	Overload protection	Limited current when detecting overcurrent: 1 to 3A/point Activated to each point. (☞ Page 51 Output modules)	
	Overheat protection	Activated in increments of 2 points. (☞ Page 51 Output modules)	
External interface		40-pin connector ☞ Page 105 40-pin connector type module	
Internal current consumption (5VDC)		290mA (TYP. all points ON)	
Weight		0.13kg	

### ■ Circuit configuration

The figure below shows the case of 32 points in the first half (F). The case of 32 points in the latter half (L) is the same.

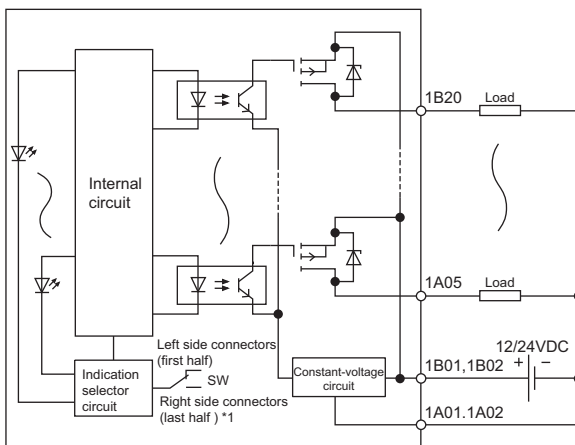

\*1 The LED indicates the first half (Y00 to Y1F) by turning the switch to the left (F), while the LED indicates the latter half (Y20 to Y3F) by turning the switch to the right (L).

## Terminal connection

Connection diagram viewed from the front of the module

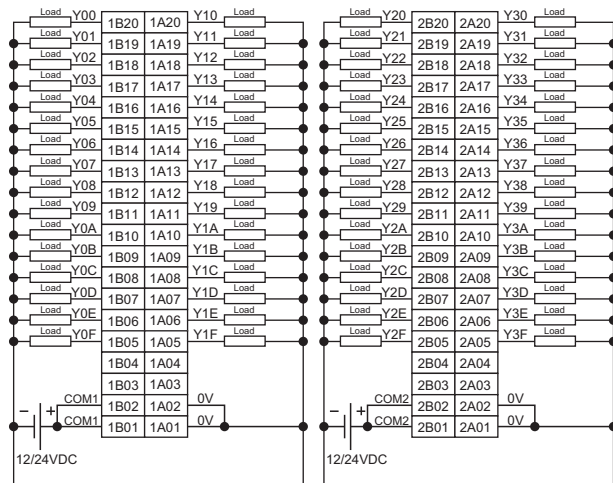

Y00 to Y1F and Y20 to Y2F are signal names.

1A01 to 1A20, 1B01 to 1B20, 2A01 to 2A20, and 2B01 to 2B20 indicate pin numbers.

1A03, 1A04, 1B03, 1B04, 2A03, 2A04, 2B03, and 2B04 are empty.

## I/O combined module

The I/O combined module is equipped with the overload protection function and overheat protection function.

Function	Description
Overload protection* <sup>1</sup>	<ul style="list-style-type: none"><li>• If the output side detects an overcurrent, current limiter operation*<sup>2</sup> is activated to limit the output current.</li><li>• For the overcurrent detection value and limit current, check the "Overload protection" column of the specifications of each module.</li><li>• If the load current falls below the overcurrent detection value, the normal operation resumes.</li></ul>
Overheat protection* <sup>1</sup>	<ul style="list-style-type: none"><li>• If an output side continues to output an overcurrent due to overload, heat is generated inside the module. If a high temperature heat is detected inside the module, the output turns off.</li><li>• The number of output points where the overheat protection function can be used simultaneously varies at each module. Check the "Overheat protection" column of the specifications of each module.</li><li>• If the heat drops, the normal operation resumes automatically.</li></ul>

\*1 This function is intended to protect the internal circuit of a module, not to protect external devices.

Additionally, an abnormal load can cause the module internal temperature to rise, resulting in deterioration of the output elements and discoloration of the case and printed-circuit board. In the event of an abnormal load, turn off the corresponding output immediately and eliminate the cause.

\*2 This operation limits an overcurrent to a certain current value, which allows a continuous output.

## RH42C4NT2P DC input/transistor output combined module

Item	Specifications	Appearance	
<b>■ Input specifications</b>			
Number of input points	32 points		
Rated input voltage	24VDC (ripple ratio: within 5%) (allowable voltage range: 20.4 to 28.8VDC)		
Rated input current	4.0mA TYP. (at 24VDC)		
ON voltage/ON current	19V or higher/3mA or higher		
OFF voltage/OFF current	6V or lower/1.0mA or lower		
Input resistance	5.3kΩ		
Response time	☞ Page 86 Input response time		
Wiring method for common	32 points/common (common terminal: 1B01, 1B02) Positive/negative common shared type		
Interrupt function	Available (can be set in the "Module Parameter")		
<b>■ Output specifications</b>			
Number of output points	32 points		
Rated load voltage	12/24VDC (allowable voltage range: 10.2 to 28.8VDC)		
Maximum load current	0.2A/point, Pilot Duty, 2A/common		
Maximum inrush current	Current is to be limited by the overload protection function.		
Leakage current at OFF	0.1mA or lower		
Maximum voltage drop at ON	0.2VDC (TYP.) 0.2A, 0.3VDC (MAX.) 0.2A		
Response time	OFF→ON		0.5ms or less
	ON→OFF		1ms or less (rated load, resistive load)
Surge suppressor	Zener diode		
Fuse	None		
External power supply	Voltage		12/24VDC (ripple ratio: within 5%) (allowable voltage range: 10.2 to 28.8VDC)
	Current		16mA (at 24VDC)/common
Wiring method for common	32 points/common (common terminal: 2A01, 2A02) Sink type		
Protection functions	Overload protection	Limited current when detecting overcurrent: 1 to 3A/point Activated to each point. (☞ Page 84 I/O combined module)	
	Overheat protection	Activated to each point. (☞ Page 84 I/O combined module)	
<b>■ Common specifications</b>			
Withstand voltage	510VACrms, 1 minute		
Isolation resistance	10MΩ or higher by isolation resistance tester		
Noise immunity	Simulator noise 500Vp-p, noise width 1μs, noise frequency 25 to 60Hz (noise simulator condition)		
Protection degree	IP2X		
Number of occupied I/O points	32 points (I/O assignment: I/O combined 32 points)		
External interface	40-pin connector ☞ Page 105 40-pin connector type module		
Internal current consumption (5VDC)	220mA (TYP. all points ON)		
Weight	0.13kg		

### ■ Derating chart (input circuit)

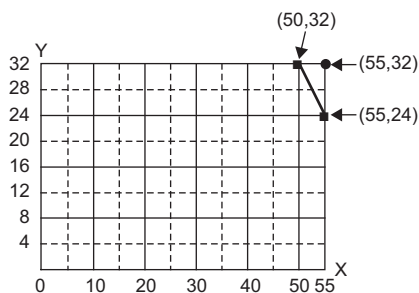

- : Input voltage 26.4V
- : Input voltage 28.8V
- X: Ambient temperature (°C)
- Y: Number of simultaneous on points (point)

## ■Circuit configuration

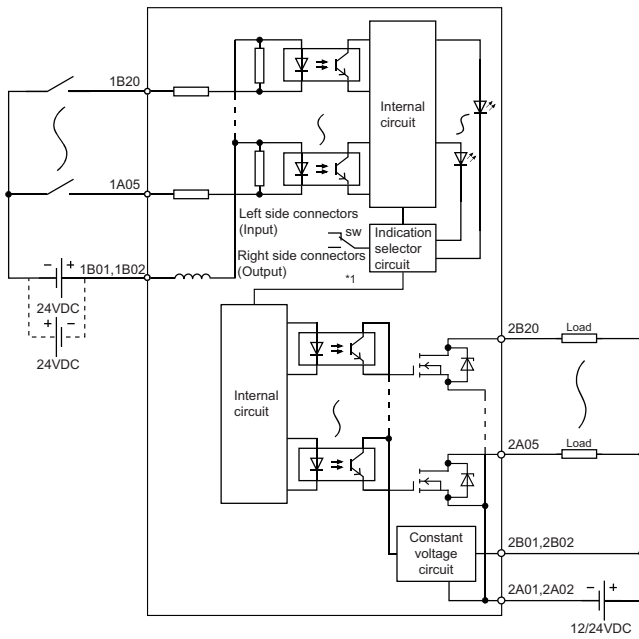

\*1 The LED indicates the input (X00 to X1F) by turning the switch to the left (F), while the LED indicates the output (Y00 to Y1F) by turning the switch to the right (L).

## ■Terminal connection

Connection diagram viewed from the front of the module

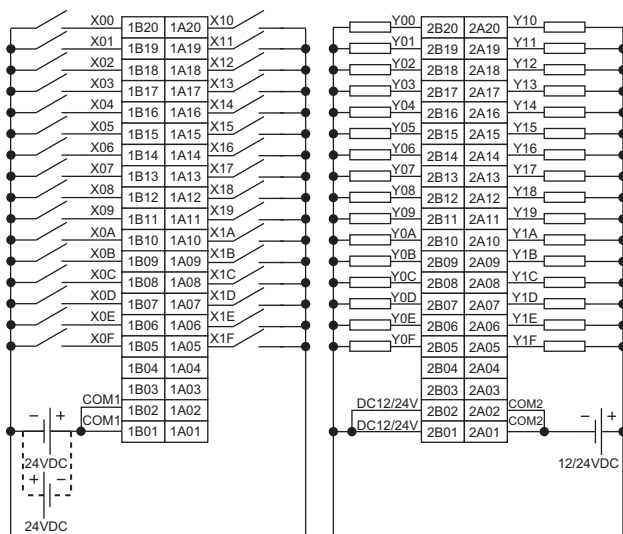

X00 to X1F and Y00 to Y1F are signal names.

1A01 to 1A20, 1B01 to 1B20, 2A01 to 2A20, and 2B01 to 2B20 indicate pin numbers.

1A01 to 1A04, 1B03, 1B04, 2A03, 2A04, 2B03, and 2B04 are empty.

## ■Input response time

Timing	Setting value								
	0.1ms	0.2ms	0.4ms	0.6ms	1ms	5ms	10ms <sup>*1</sup>	20ms	70ms
OFF→ON (MAX)	0.1ms	0.2ms	0.4ms	0.6ms	1ms	5ms	10ms	20ms	70ms
ON→OFF (MAX)	0.2ms	0.3ms	0.5ms	0.7ms	1ms	5ms	10ms	20ms	70ms

\*1 The default value of input response time is 10ms.



# Blank cover module

## RG60 blank cover module

Item		Specifications	Appearance
Number of occupied I/O points		Default: 16 points (can be changed to 0, 16, 32, 48, 64, 128, 256, 512, or 1024 points in the I/O assignment setting of the system parameters)	
Application		Used for dust prevention in the space where an I/O module is not mounted (especially the empty slot between modules).	
External dimensions	Height	106mm	
	Width	27.8mm	
	Depth	110mm	
Weight		0.07kg	
—		—	



3



Mount the blank cover module with the connector cover of the base unit attached.

## 3.2 Function List

This section lists the functions of the I/O module.

Item	Description	Reference
Input response time setting	Allows changing the input response times of input modules by each input point. The input modules take in external input for the set input response time.	Page 115 Input Response Time Setting
Interrupt input function	Generates an interrupt from an input module.	Page 116 Interrupt Input Function
In-error output mode setting	Allows selection of whether the CPU module clears or holds output to the output module when a stop error occurs.	Page 117 In-Error Output Mode Setting
Output ON number count function	Counts the number of ON times for each output point within the range of 0 to 4294967295. The integration value is held even if the output module is powered off.	Page 118 Output ON Number Count Function
Inter-module synchronization function	Synchronizes input and output with multiple modules on which the inter-module synchronization function is enabled.	 MELSEC iQ-R Inter-Module Synchronization Function Reference Manual
Online module change function	Allows addition of a module or replacement of a module mounted on a main base unit or an extension base unit while controlling the system at power-on.	 MELSEC iQ-R Online Module Change Manual

## 3.3 Buffer Memory

The buffer memory in an I/O module consists of only system areas except for areas of Number of output ON times possessed by a contact output module. Reading/writing data from/to the system areas may cause malfunction.

For details on buffer memory areas of Number of output ON times, refer to the following.

 Page 118 Buffer memory

# 4 PROCEDURES BEFORE OPERATION

---

This chapter describes the procedures before operation.

## 1. Mounting a module

Mount the I/O module in any desired configuration.

 Page 91 SYSTEM CONFIGURATION

## 2. Wiring

Perform wiring of external devices to the I/O module.

 Page 104 Wiring

## 3. Adding a module

Add the I/O module to a module configuration by using the engineering tool. For details, refer to the following.

 GX Works3 Operating Manual

## 4. Module settings

Perform various settings of the module by using the engineering tool.

 Page 110 PARAMETER SETTINGS

## 5. Programming

Create a program.

 GX Works3 Operating Manual

# MEMO

---

# 5 SYSTEM CONFIGURATION

This chapter describes the system configuration of the I/O module.

## 5.1 System Configuration

### System configuration example when I/O modules are used

The following figure shows an example of the system configuration when I/O modules are used.

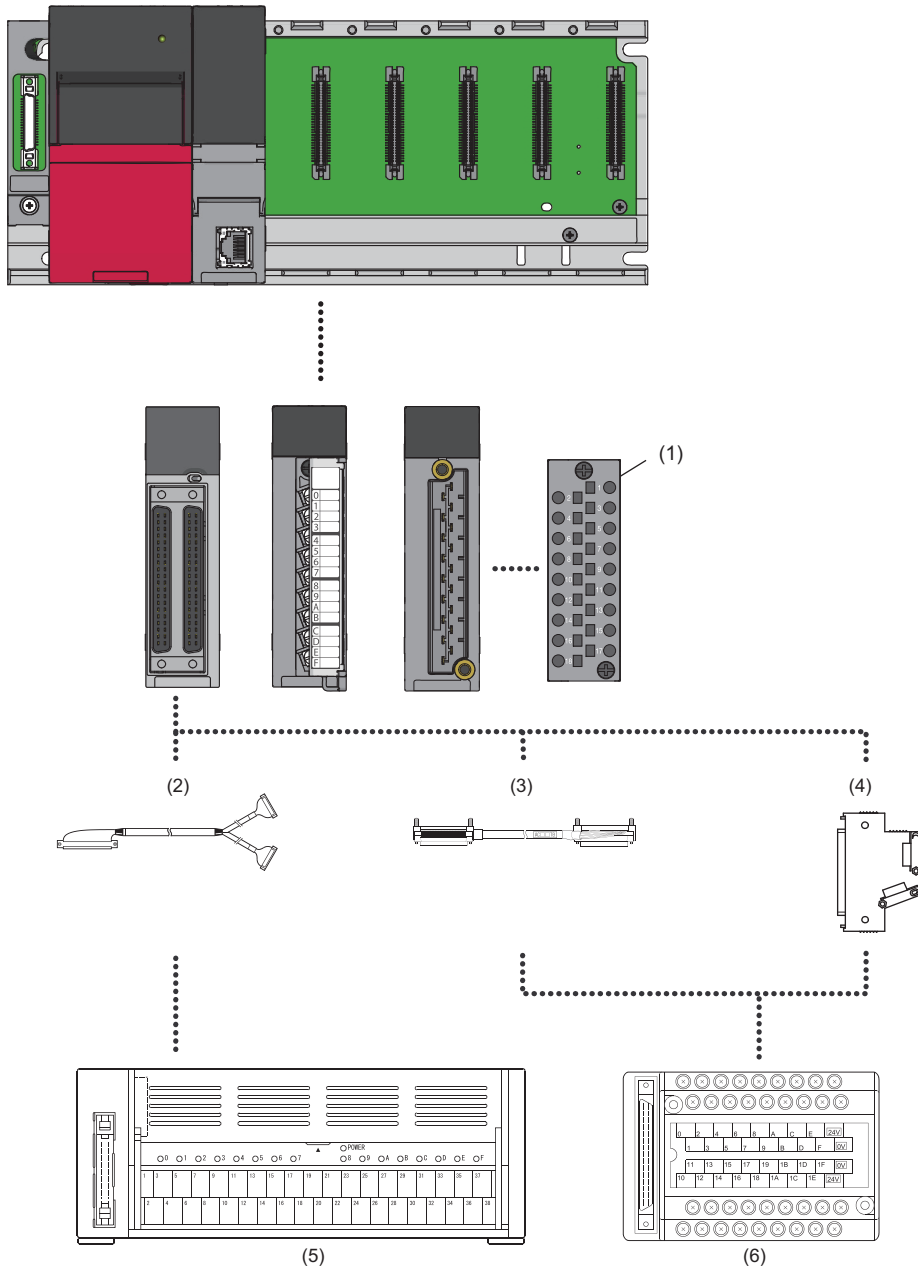

- (1): Spring clamp terminal block
- (2): Dedicated cable with connector (relay terminal module) (optional)
- (3): Dedicated cable with connector (connector/terminal block converter module) (optional)
- (4) Connector
- (5): Relay terminal module (optional)
- (6): Connector/terminal block converter module (optional)

## Recommended optional items

To perform the module wiring easier, the following products are prepared as optional items.

### ■Connector/terminal block converter module and dedicated cable with connector

Used for the easy wiring from a connector type I/O module to an external wiring terminal block.

 Page 129 Connector/terminal block converter modules

### ■Relay terminal module and dedicated cable with connector

Used as a substitute for the relay terminal blocks and relays in a control panel, which reduces the man-hours for wiring among the programmable controllers, relay terminal blocks, and relays.

For details on the relay terminal module and dedicated cable with connector, refer to the following.

 Relay Terminal Module User's Manual (Hardware) A6TE2-16SRN

### ■Spring clamp terminal block

Used by mounting it on a terminal block type I/O module. The man-hours for wiring can be reduced considerably because the screw tightening is not required in wiring.

For details on the spring clamp terminal block, refer to the following.

 Before Using the Product (BCN-P5999-0209)

## 5.2 Applicable Systems

---

### Compatible software version

---

To ensure compatibility of the software version, always update GX Works3 to the latest version.

# 6 INSTALLATION AND WIRING

This chapter describes the installation and wiring of the I/O modules.

## 6.1 Before Using the I/O Modules

### Input modules

#### Precautions common to all input modules

##### ■Number of simultaneous ON points

The number of input points that can be turned on at the same time varies depending on the input voltage and ambient temperature. For details, refer to the derating chart of the specifications of each input module.

☞ Page 21 SPECIFICATIONS

#### Precautions when using the DC input module

##### ■Measures against back EMF

When connecting an inductive load, connect a diode in parallel with the load. Use the diode that satisfies the following conditions:

- A reverse breakdown voltage is more than ten times as high as the circuit voltage.
- A forward current is more than twice as high as the load current.

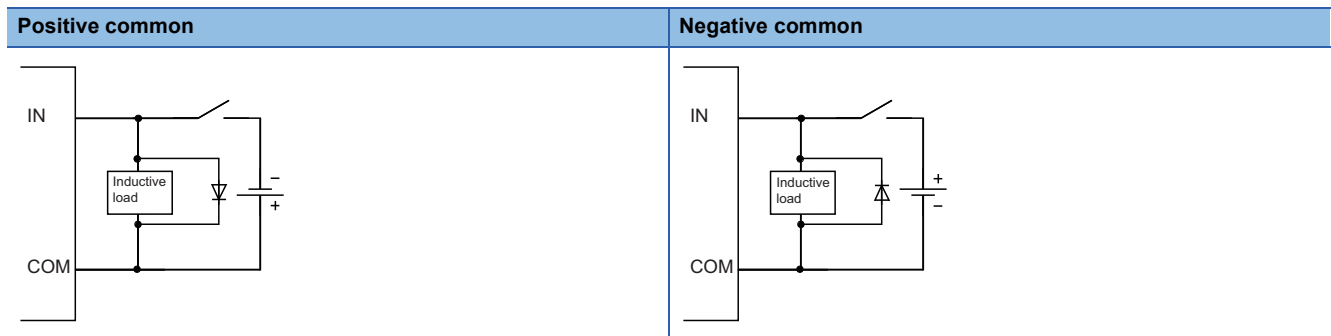



# Output modules

## Precautions common to all output modules

### ■Maximum switching frequency when L load is driven

The maximum switching frequency imposes a limit on the use; an ON state or an OFF state must not be changed without an interval of at least one second.

### ■Load to be connected

When connecting a counter or timer utilizing a DC-DC converter as a load of the output module, select an output module whose maximum load current is higher than the inrush current of a load to be connected. If the selection is based on the average current of a load, an inrush current flows cyclically from the load while the output module is in an ON state or in operation, which can cause failure of the module. If necessary to select a module on the basis of the average current, to alleviate the effect of the inrush current, take any of the following corrective actions:

- Connecting a resistor in series with the load

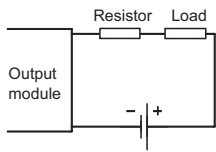

- Connecting an inductor in series with the load

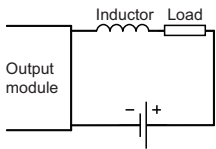

## Precautions when using the transistor output module

### ■Measures against reverse current

In the following connections, a reverse current flows to the output element, which can cause failure.

When wiring, set up diodes as the following figures show:

- When connecting transistor output modules in parallel

Sink type	Source type
<p>A circuit diagram showing two transistor output modules connected in parallel. Each module has terminals labeled OUT1, OUT2, and COM. The COM terminals of both modules are connected to a common ground. The OUT1 and OUT2 terminals of both modules are connected to a load. Diodes are connected from each OUT1 and OUT2 terminal to the common COM line to prevent reverse current flow.</p>	<p>A circuit diagram showing two transistor output modules connected in parallel. Each module has terminals labeled OUT1, OUT2, and COM. The COM terminals of both modules are connected to a common ground. The OUT1 and OUT2 terminals of both modules are connected to a load. Diodes are connected from the common COM line to each OUT1 and OUT2 terminal to prevent reverse current flow.</p>

- When providing another circuit in parallel with a transistor output module

Sink type	Source type
<p>A circuit diagram showing a transistor output module with terminals OUT and COM. The COM terminal is connected to a common ground. The OUT terminal is connected to a load. An additional circuit, enclosed in a dashed box, is connected in parallel with the load. A diode is connected from the OUT terminal to the common ground to prevent reverse current flow.</p>	<p>A circuit diagram showing a transistor output module with terminals OUT and COM. The COM terminal is connected to a common ground. The OUT terminal is connected to a load. An additional circuit, enclosed in a dashed box, is connected in parallel with the load. A diode is connected from the common ground to the OUT terminal to prevent reverse current flow.</p>

## ■ Measures against back EMF

When connecting an inductive load, connect a diode in parallel with the load.

Use the diode that satisfies the following conditions:

- A reverse breakdown voltage is more than ten times as high as the circuit voltage.
- A forward current is more than twice as high as the load current.

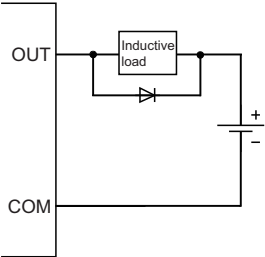
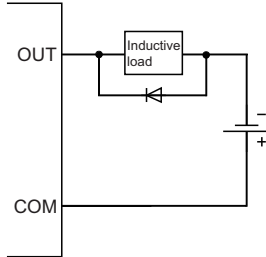
Sink type	Source type
	

## ■ About element protection of the output module

If excessive noise affects the terminals of the output module, the output may be turned on to help the protection of the output element. Adjust the voltage between terminals of the output module to fall within the operating load voltage range by take measures such as the following:

- To use an inductive load such as a relay, a surge suppressor is required on the load side as well. Take appropriate measures with the measures against back EMF as a guide. (📖 Page 96 Measures against back EMF)
- To prevent excessive noise, avoid installing power cables together with I/O cables.

## Precautions when using the contact output module

When using the contact output module, carefully consider the following points:

- Relay life (contact switching life)
- Influence on the relay life by a connected load
- Measures against back EMF

### ■ Relay life (contact switching life)

Applicable module.....RY10R2, RY10R2-TS, RY18R2A

The relay life varies depending on the environment where a module is used. When using a module, take the use environment into consideration.

The relay life curve below shows the actual service values, not the guaranteed values. Since an actual contact switching life may be shorter than the relay life curve, replace the module with a sufficient margin for the life.

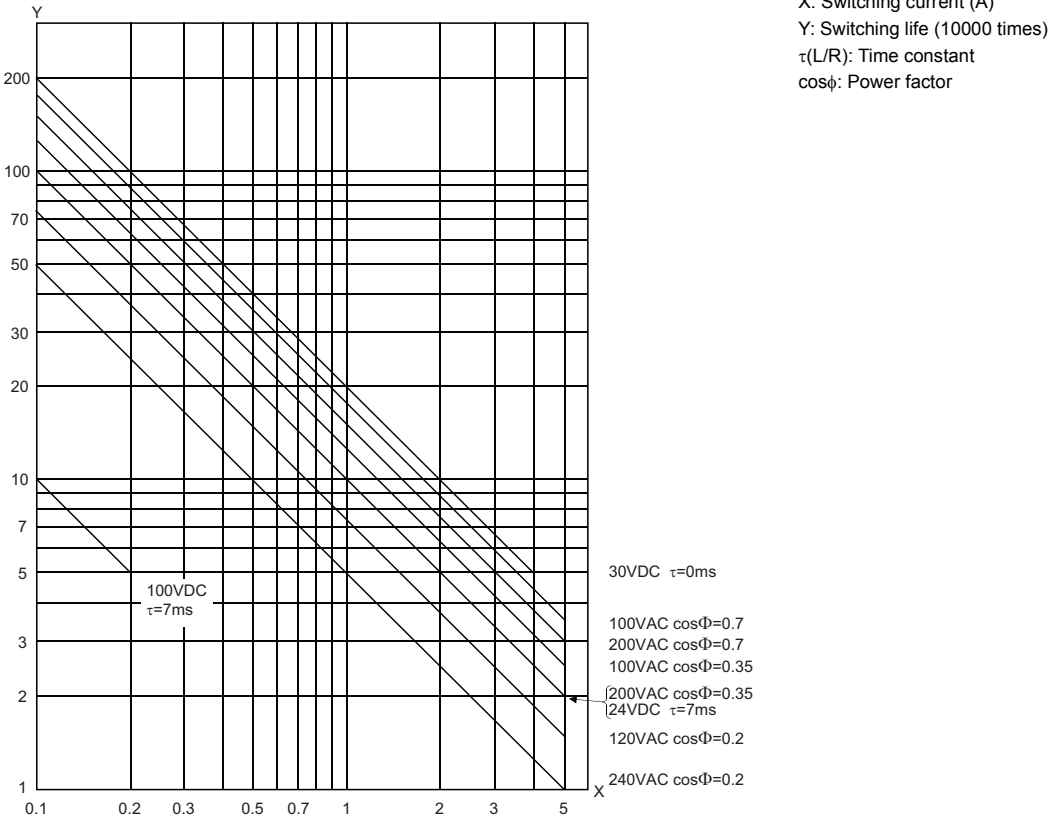

Use environment	Contact switching life
Rated switching voltage/current load	100 thousand times
1.5A at 200VAC, 1A at 240VAC ( $\text{COS}\phi = 0.7$ )	100 thousand times
0.4A at 200VAC, 0.3A at 240VAC ( $\text{COS}\phi = 0.7$ )	300 thousand times
1A at 200VAC, 0.5A at 240VAC ( $\text{COS}\phi = 0.35$ )	100 thousand times
0.3A at 200VAC, 0.15A at 240VAC ( $\text{COS}\phi = 0.35$ )	300 thousand times
1A at 24VDC, 0.1A at 100VDC ( $L/R = 7\text{ms}$ )	100 thousand times
0.3A at 24VDC, 0.03A at 100VDC ( $L/R = 7\text{ms}$ )	300 thousand times

## ■ Influence on the relay life by a connected load

An actual relay life can be substantially shorter than the relay life curve depending on the type of a connected load and the characteristics of its inrush current.

☞ Page 97 Relay life (contact switching life)

The inrush current generated by a connected load can lead to contact welding of the module. To prevent shortening of the relay life and contact welding, take the following measures:

- Considering the possibility of a high inrush current, select a load so that the inrush current generated by the connected load falls within the range of the rated current of the module.
- Connect a relay capable of withstanding the inrush current, outside the module.

The following table lists the relations between typical loads and each inrush current.

Select a load so that the inrush current,  $i$ , and rated current,  $i_o$ , fall within the range of the rated switching current described in the module specifications. In some loads, the inrush current flows for a long time.

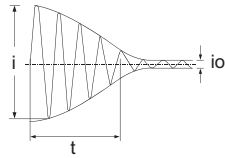
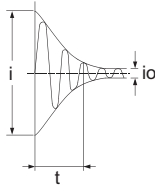
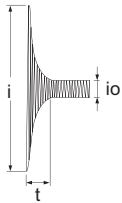
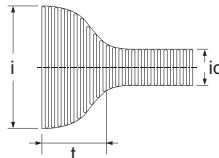
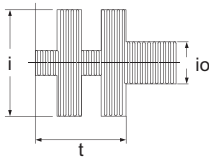
Load type	Waveform	Inrush current $i$ /rated current $i_o$	Waveform	Inrush current $i$ /rated current $i_o$
Inductive load	Load of a solenoid  $i$ : Inrush current $i_o$ : Rated current $t$ : 0.07 to 0.1 seconds	Approx. 10 to 20 times	Load of an electromagnetic contactor  $i$ : Inrush current $i_o$ : Rated current $t$ : 0.017 to 0.033 seconds (1 to 2 cycle)	Approx. 3 to 10 times
Lamp load	Load of an incandescent lamp  $i$ : Inrush current $i_o$ : Rated current $t$ : Approx. 0.33 seconds	Approx. 3 to 10 times	Load of a mercury lamp  $i$ : Inrush current $i_o$ : Rated current $t$ : 180 to 300 seconds (3 to 5 minutes)	Approx. 3 times <sup>*1</sup>
	Load of a fluorescent lamp  $i$ : Inrush current $i_o$ : Rated current $t$ : within 10 seconds	Approx. 5 to 10 times	—	—

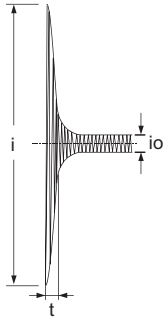
Load type	Waveform	Inrush current i/rated current io	Waveform	Inrush current i/rated current io
Capacitive load	Capacitive load*2  i: Inrush current io: Rated current t: 0.008 to 0.33 seconds (0.5 to 2 cycle)	Approx. 20 to 40 times	—	—

\*1 A typical discharge lamp circuit is configured with a combination of discharge tubes, transformers, choke coils, capacitors and others. Because of this, be especially careful of the case of a high power factor and a low power supply impedance, where the inrush current flowing into the output module can be 20 to 40 times as high as the rated current.

\*2 When the wiring is long, be careful with the cable capacity as well.

## ■Measures against back EMF

Provide a contact protection circuit for an extended contact life, noise prevention at contact close, and reduction of the carbides and nitric acids formed by an arc discharge.

An incorrect circuit involves a high risk of contact welding.

With the contact protection circuit, the recovery time may be delayed.

The following table shows typical examples of the contact protection circuit.

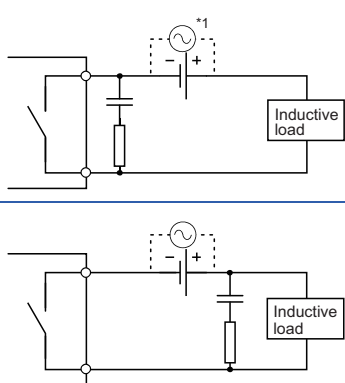
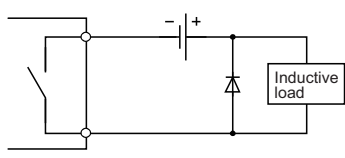
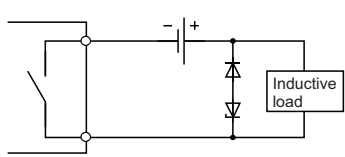
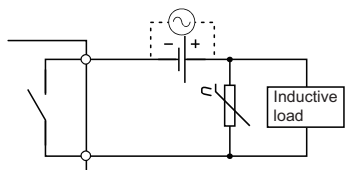
Circuit example	Element selection criteria	Remarks
Capacitor + resistance method (CR method) 	Estimate the constants of a capacitor and resistance with the following as a guide. Some differences, however, may arise from a variation in the nature and characteristics of the load. <ul style="list-style-type: none"> <li>• Capacitor: 0.5 to 1 (<math>\mu\text{F}</math>) for a load current of 1A</li> <li>• Resistance: 0.5 to 1 (<math>\Omega</math>) for a power supply voltage of 1V</li> </ul> Use a capacitor whose withstand voltage is equal to or higher than the rated voltage. In an AC circuit, use a capacitor with no polarity.	When a relay or solenoid is used as the load, the recovery time is delayed. A capacitor has the effect of reducing a discharge at contact OFF, while a resistance has the effect of limiting a current at contact ON.
Diode method 	Use a diode that satisfies the following conditions: <ul style="list-style-type: none"> <li>• A reverse breakdown voltage is more than ten times as high as the circuit voltage.</li> <li>• A forward current is more than twice as high as the load current.</li> </ul>	The recovery time is delayed than the CR method.
Diode + zener diode method 	Use a zener diode whose zener voltage is higher than the power supply voltage.	This method is suitable for the case where the diode method results in a substantial delay in the recovery time.
Varistor method 	Select a varistor whose cut-off voltage ( $V_c$ ) satisfies the following conditions: <ul style="list-style-type: none"> <li>• <math>V_c &gt; \text{power supply voltage} \times 1.5 \text{ (V)}</math></li> <li>• <math>V_c &gt; \text{power supply voltage} \times 1.5 \text{ (V)} \times \sqrt{2}</math> (on AC power supply)</li> </ul> Note that selecting an element of a too high $V_c$ leads to a weaker effect.	The recovery time is a little delayed.

\*1 On AC power supply, the impedance of the CR needs to be sufficiently higher than that of the load (for preventing errors due to the leakage current of the CR).

### Point

- Avoid using contact protection circuits like the following. Although highly effective in reducing the arc at current cutoff, a charge current flows into the capacitor when the contact turns on or off, which leads to the risk of contact welding. A DC inductive load, generally considered to be more difficult to open and close than a resistive load, can achieve the same performance of a resistive load in an appropriate configuration of the protection circuit.

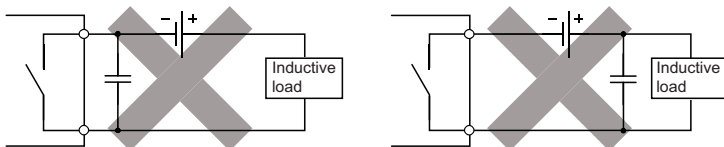

- Install the protection circuit near the load or contact (module). A long distance between them may inhibit the effect of the protection circuit. As a guide, install it at a distance of no more than 50cm.

## Precautions when using the triac output module

Because of characteristics of a triac, a sudden change of voltage or current may cause unstable operations of a triac used for the triac output module.

Whether the voltage or current change causes a problem differs depending on an individual part (each triac), thus check the following when using the triac output module.

### ■Checking of the load current

When the current consumption is equal to or smaller than the minimum load current and the margin is low by using an inductive load such as a solenoid valve, a triac may not turn on or off properly. In that case, an action such as connecting a bleeder resistance is required.

For detail on actions, refer to the following.

☞ Page 123 Output Circuit Troubles and Corrective Actions

### ■Precautions on a full-wave rectifier load

The load current of a full-wave rectifier load forms waves similar to rectangular waves as shown below.

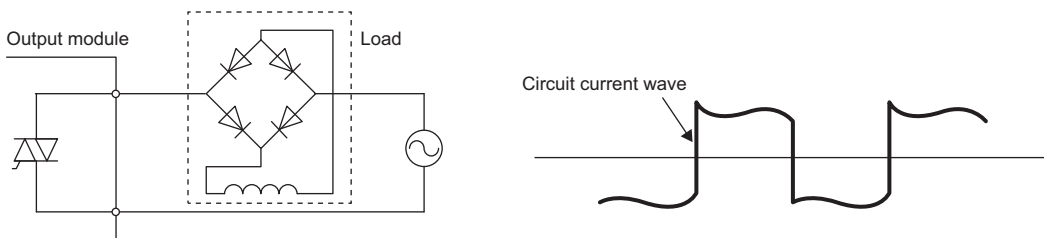

A triac may not operate properly if the current forms rectangular waves associated with sudden current changes. To avoid it, use a load with which the load current does not form rectangular waves.

## ■Measures for connecting an inductive load

To connect an inductive load, take measures to reduce noise to the side where the load is connected as shown below.

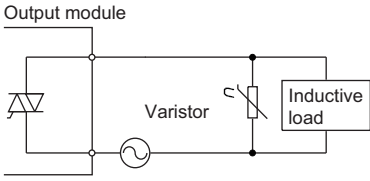
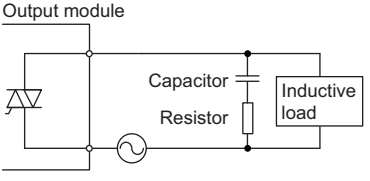
Circuit example	Element selection criteria	Remarks
Varistor method 	Select a varistor whose cut-off voltage ( $V_c$ ) satisfies the following conditions: • $V_c > \text{Power supply voltage} \times 1.5 (V) \times \sqrt{2}$ Note that selecting an element of a too high $V_c$ leads to a weaker effect.	The recovery time is a little delayed.
Capacitor + resistance method (CR method) 	Estimate the constants of a capacitor and resistance with the following as a guide. Some differences, however, may arise from a variation in the nature and characteristics of the load. • Capacitor: 0.5 to 1 ( $\mu\text{F}$ ) for a load current of 1A • Resistance: 0.5 to 1 ( $\Omega$ ) for a power supply voltage of 1V Use a capacitor whose withstand voltage is equal to or higher than the rated voltage. Use a capacitor with no polarity.	When a relay or solenoid is used as the load, the recovery time is delayed.

## ■Measures for connecting an inductive load (when installing a contact between the load and the output terminal)

To install a contact (such as an interlock) between the load and the output terminal, take measures to reduce noise as shown below.

Though measures (varistor method, capacitor + resistance method) are normally taken to the load side, in some cases, it is more efficient to take the measures to the module side considering the contact effect.

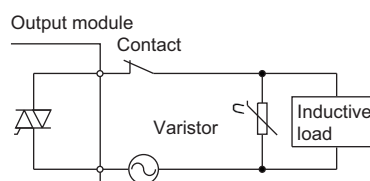
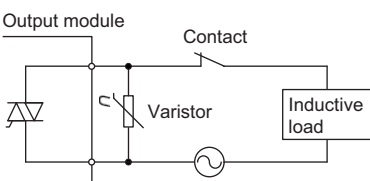
Circuit example	Element selection criteria	Remarks
Varistor method <ul style="list-style-type: none"> <li>• Measure taken to the load side</li> </ul>  <ul style="list-style-type: none"> <li>• Measure taken to the module side</li> </ul> 	Select a varistor whose cut-off voltage ( $V_c$ ) satisfies the following conditions: • $V_c > \text{Power supply voltage} \times 1.5 (V) \times \sqrt{2}$ Note that selecting an element of a too high $V_c$ leads to a weaker effect.	The recovery time is a little delayed.



## I/O combined module

This section describes the precautions specific to the I/O combined module.

The precautions other than the following are the same as the input module and output module. (☞ Page 94 Input modules, Page 95 Output modules)

### I/O numbers of the I/O combined module

The I/O combined module assigns the same I/O number to each input and output.

The same number for the input number and output number saves the I/O numbers in use.

Input (X)	Output (Y)	Number of points
X00	Y00	32 points
⋮	⋮	
X1F	Y1F	

## 6.2 Wiring

### 18-point screw terminal block type module

#### Precautions

- When wiring the terminal block, be sure to use a solderless terminal with a width of 0.8mm or less. In addition, one terminal part allows connection of up to two solderless terminals.
- A solderless terminal with an insulation sleeve cannot be used for the terminal block. To prevent a short-circuit due to a loose terminal block screw, coating the wire connection part with a mark tube or insulation tube is recommended.
- For the wire to be connected to the terminal block, use the following.

Applicable wire size	Material	Temperature rating
0.3 to 0.75mm <sup>2</sup> (22 to 18 AWG) (stranded wire) Outside diameter: 2.8mm or less* <sup>1</sup>	Copper	75°C or greater

- Use the UL listed solderless terminal, R1.25-3.
- Tighten the terminal block screws within the following specified torque range.

Screw	Tightening torque range
Terminal screw (M3)	0.42 to 0.58N·m
Terminal block mounting screw (M3.5)	0.66 to 0.89N·m

- \*1 Use the wire of 0.75mm<sup>2</sup> or smaller. If the wire of larger than 0.75mm<sup>2</sup> is used, the sideways overhang of wiring becomes large, contacts with the terminal block or connector of an adjacent module, and results in applying stress to the module. Note that the wire of 0.3 to 1.5mm<sup>2</sup> (22 to 16 AWG) can be used when a spring clamp terminal block (Q6TE-18SN) is used instead. To use a wire of larger size than the one described in the above table, take a measure by using FA goods of Mitsubishi Electric Engineering Co., Ltd. (such as FA-TB161AC+ FA-CBL20D).

#### Wiring method, installation procedure, and removal procedure of the terminal block

For the wiring method, installation procedure, and removal procedure, refer to the following.

 MELSEC iQ-R Module Configuration Manual

# 40-pin connector type module

## Precautions

- Use copper wire with a temperature rating of 75°C or higher for the connector.
- Tighten the connector screws within the following specified torque range.

Screw	Tightening torque range
Connector screw (M2.6)	0.20 to 0.29N·m

## Applicable connectors

40-pin connectors to be used for an input module, output module, and I/O combined module are sold separately.

The following table lists the applicable connectors and models, and the reference products of a crimping tool and pressure-displacement tool.

### ■40-pin connectors

Type	Model	Applicable wire size
Soldering type connector (straight type)	A6CON1*1	0.088 to 0.3mm <sup>2</sup> (28 to 22 AWG) (stranded wire)
Crimping type connector (straight type)	A6CON2	0.088 to 0.24mm <sup>2</sup> (28 to 24 AWG) (stranded wire)
IDC type connector (straight type)	A6CON3	28 AWG (stranded wire) 30 AWG (solid wire) 1.27mm pitch flat cable
Soldering type connector (dual purpose (straight/oblique) type)	A6CON4*1	0.088 to 0.3mm <sup>2</sup> (28 to 22 AWG) (stranded wire)

\*1 Use wire with a sheath outside diameter of 1.3mm or less when using the 40 pins. Select appropriate cables according to the current value used.

### ■40-pin connector crimping tool and pressure-displacement tool

Type	Model	Contact
Crimping tool	FCN-363T-T005/H	FUJITSU COMPONENT LIMITED
Pressure-displacement tool	FCN-367T-T012/H (locator plate)	
	FCN-707T-T001/H (cable cutter)	
	FCN-707T-T101/H (hand press)	

For how to wire the connector and how to use the crimping tool and pressure-displacement tool, contact the manufacturer.

## Wiring method, installation procedure, and removal procedure of the connectors

For the wiring method, installation procedure, and removal procedure, refer to the following.

📖 MELSEC iQ-R Module Configuration Manual

## Spring clamp terminal block (lever type)

### Precautions

- Use bar solderless terminals for wiring to the terminal block. If a stripped wire is inserted into a wire insertion opening, the wire cannot be securely clamped.
- For how long the wire should be stripped, follow the specifications of the bar solderless terminal used. To attach a bar solderless terminal to a wire, use a crimping tool.

### List of bar solderless terminals

The following table lists recommended bar solderless terminals.

Product name		Model	Applicable wire size	Length of peeling	Contact
Bar solderless terminal	With insulation sleeve	A10.34-10TQ	0.34mm <sup>2</sup>	12mm	PHOENIX CONTACT GmbH & Co. KG
		A10.5-10WH	0.5mm <sup>2</sup>	13mm	
		A10.75-10GY	0.75mm <sup>2</sup>	13mm	
	Without insulation sleeve	A0.5-10	0.5mm <sup>2</sup>	10mm	
		A0.75-10	0.75mm <sup>2</sup>	10mm	
		A1-10	1.0mm <sup>2</sup>	10mm	
		A1.5-10	1.5mm <sup>2</sup>	10mm	
Bar solderless terminal tool		CRIMPFOX6	—		

## Processing method of the cable terminal

Strip the cable from the tip to connect a bar solderless terminal at the stripped area. For how long the cable should be stripped, follow the specifications of the bar solderless terminal used. Stripping the cable too long may cause electric shock or short circuit between adjacent terminals because the conductive part sticks out of the terminal block. Stripping the cable too short may cause a poor contact to the spring clamp terminal part.

## Wiring method and installation/removal procedures of the cables and connectors

For the wiring method, installation procedure, and removal procedure, refer to the following.

 MELSEC iQ-R Module Configuration Manual

# 6.3 Input Wiring Examples

The following figures show examples of wiring between the DC input module and connectable DC input devices (DC output type).

## Wiring example for contact output type

The wiring example for the DC input module (1) and the contact output type (2) is shown below.

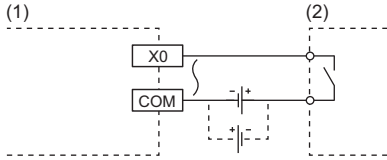

## Wiring example for DC 2-wire type

The wiring example for the DC input module (1) and the DC 2-wire type (2) is shown below.

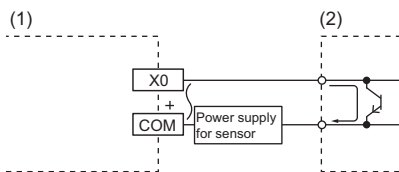

## Wiring example for transistor output type

- The wiring example for the DC input module (1) and the NPN open collector output type (2) is shown below.

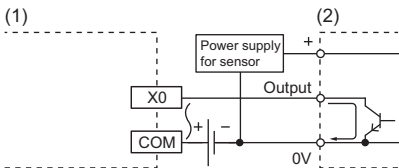

- The wiring example for the DC input module (1) and the NPN current output type (2) is shown below.

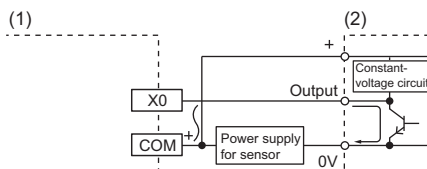

- The wiring example for the DC input module (1) and the PNP current output type (2) is shown below.

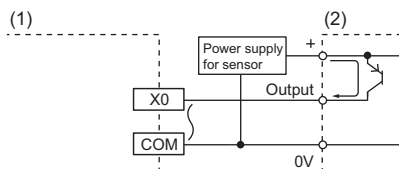

## Wiring example for voltage output type

The wiring example for the DC input module (1) and the voltage output type (2) is shown below.

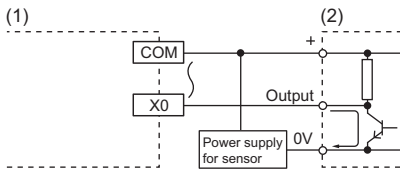

### Point

When connecting to the voltage output type (1) sensor, avoid the wiring as shown below.

In the wiring below, a current flows into the DC input module through the pull-up resistor (2) in the sensor. As a result, an input current may not reach the ON current of the DC input module (3), which does not change the input signal to an ON state.

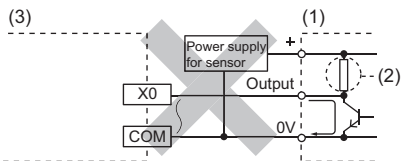



# 7 PARAMETER SETTINGS

---

This chapter describes the parameter settings of the I/O modules. Setting parameters here eliminates the need to program them.

## 7.1 Parameter Setting Procedure

---

1. Add the I/O module to the setting in the engineering tool.  
 [Navigation window] ⇒ [Parameter] ⇒ [Module Information] ⇒ Right-click ⇒ [Add New Module]
2. The parameter setting consists of four items: the input response time setting, interrupt setting, setting of error-time output mode, and refresh setting. Select these items from the tree window below to set them.  
 [Navigation window] ⇒ [Parameter] ⇒ [Module Information] ⇒ Module model name ⇒ [Module Parameter]
3. Write the setting into the CPU module using the engineering tool.  
 [Online] ⇒ [Write to PLC]
4. Reset the CPU module or turn off and on the power to reflect the setting.



# Input response time setting

Set the input response time setting (cannot be set for the AC input module).

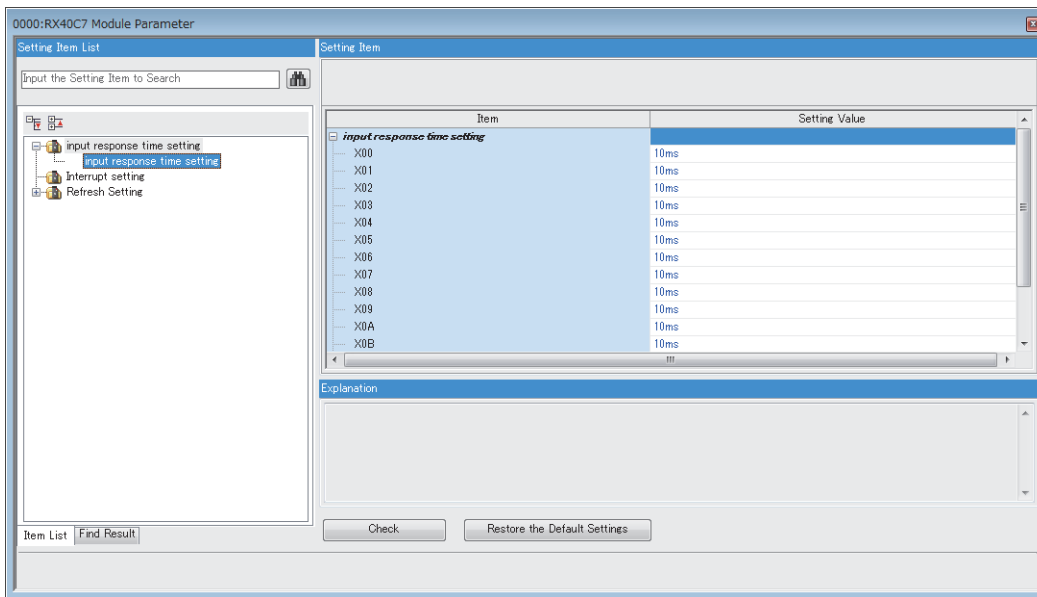

Item		Setting range	Reference
input response time setting	X00 to X3F	<ul style="list-style-type: none"> <li>• No Setting<sup>*1</sup></li> <li>• 10micro-s<sup>*2</sup></li> <li>• 20micro-s<sup>*1</sup></li> <li>• 50micro-s<sup>*1</sup></li> <li>• 0.1ms</li> <li>• 0.2ms</li> <li>• 0.4ms</li> <li>• 0.6ms</li> <li>• 1ms</li> <li>• 5ms</li> <li>• 10ms</li> <li>• 20ms</li> <li>• 70ms</li> </ul>	Page 115 Input Response Time Setting

\*1 The value can be set only for a DC high-speed input module.

\*2 The value can be set only for the RX41C6HS and RX61C6HS.

# Interrupt setting

Set the interrupt function for the input module.

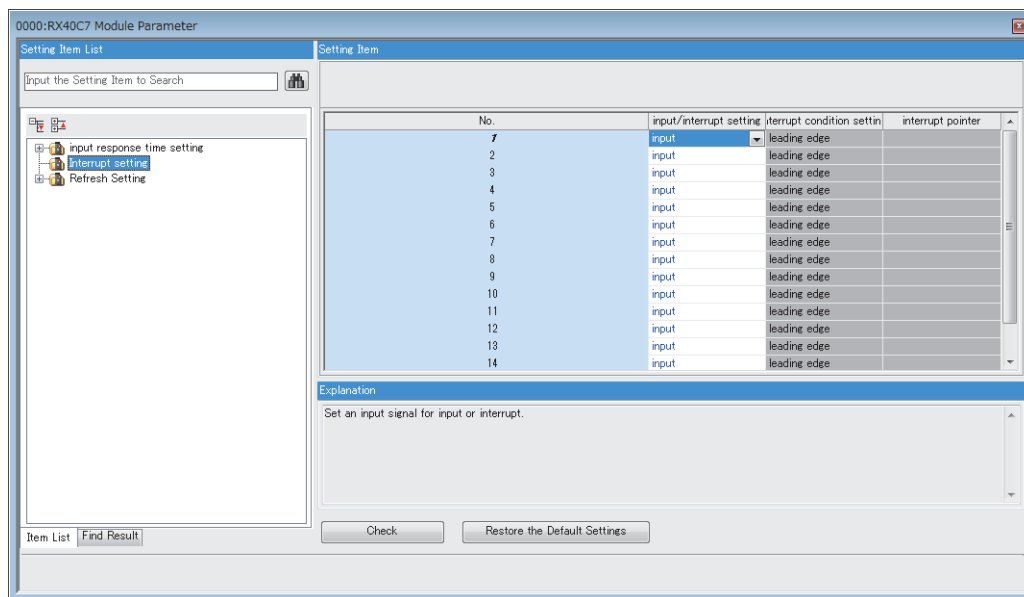

Item	Setting range	Reference
input/interrupt setting	<ul style="list-style-type: none"> <li>input</li> <li>interrupt</li> </ul>	Page 116 Interrupt Input Function
interrupt condition setting	<ul style="list-style-type: none"> <li>leading edge</li> <li>trailing edge</li> <li>leading edge/trailing edge</li> </ul>	
interrupt pointer	I0 to I15, I50 to I1023 <sup>*1</sup>	

\*1 For details on the available interrupt pointers, refer to the following.

📖 MELSEC iQ-R CPU Module User's Manual (Application)

# Setting of error-time output mode

Set the in-error output setting.

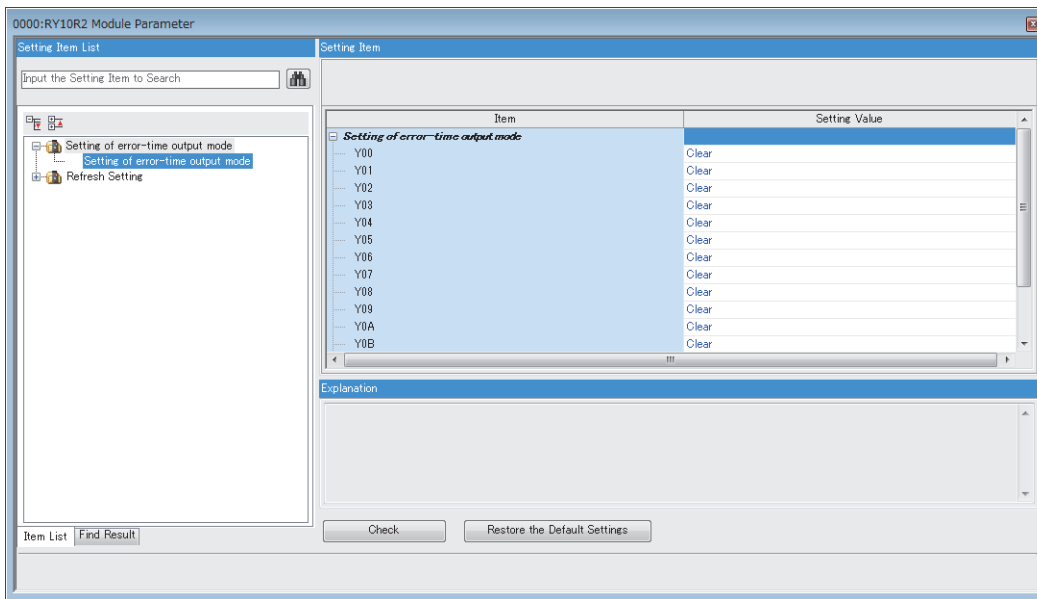

Item	Setting range	Setting range	Reference
Setting of error-time output mode	Y0 to Y3F	<ul style="list-style-type: none"> <li>• Clear</li> <li>• Hold</li> </ul>	Page 117 In-Error Output Mode Setting

# Refresh setting

Set the refresh timing of the refresh destination specified.

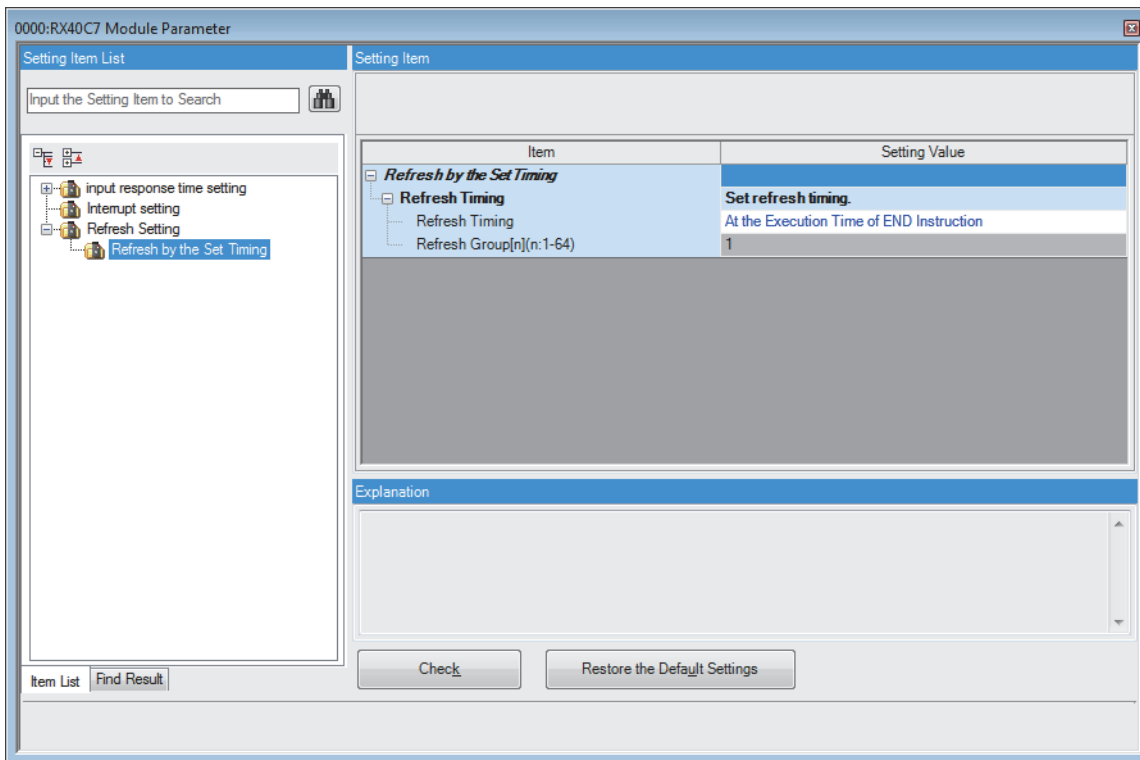

Setting value	Description
At the Execution Time of END Instruction	Refresh takes place at the time of the END processing of the CPU module.
At the execution time of specified program	Refresh takes place at the time of the execution of the program specified in "Refresh Group[n](n: 1-64)".

# 8 FUNCTIONS

## 8.1 Input Response Time Setting

This function allows changing the input response times of input modules by each input point. The input modules take in external input for the set input response time.

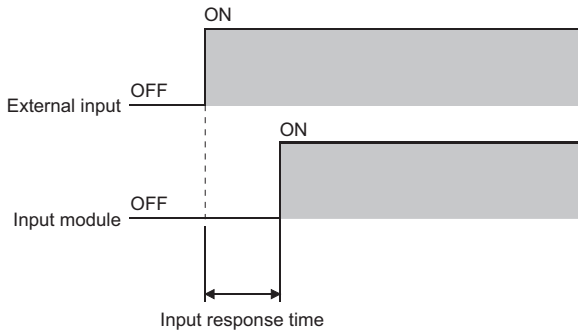

### Setting method

Set the input response time from "input response time setting".

[Navigation window] ⇒ [Parameter] ⇒ [Module Information] ⇒ Module model name ⇒ [Module Parameter] ⇒ [input response time setting]

#### ■ Input response time and pulse width of noise to be eliminated

The input module may take in noise as an input depending on the input response time setting.

When setting the input response time, consider the environment where the module is used and refer to the following table that shows the pulse width of noise to be eliminated (pulse width that is not taken in as an input).

Input response time setting value	1ms	5ms	10ms	20ms	70ms
Pulse width of noise to be eliminated (reference value)	0.3ms	1.5ms	4ms	8ms	35ms

## 8.2 Interrupt Input Function

---

This function generates an interrupt from an input module.

### Operation

An interrupt operation depends on the condition set in module parameters. In addition, an interrupt condition can be set for each point.

When "interrupt condition setting" is set to "leading edge/trailing edge", an interrupt factor occurred during execution of an interrupt program is held only once, and the second and subsequent factors are ignored.

If "fall → rise" occurs during execution of an interrupt program to be triggered by a rising edge, the second rising edge does not trigger the interrupt program. Because of this, provide an interval between on and off of the interrupt input (also same as "fall → rise → fall").

In addition, a continuous interrupt input of signals with a short ON width and OFF width causes frequent halts of the main routine program. Adjust the ON width and OFF width for interrupt input not to interfere with the execution of the main routine program.

### Setting method

Set the interrupt method from "Interrupt setting".

 [Navigation window] ⇒ [Parameter] ⇒ [Module Information] ⇒ Module model name ⇒ [Module Parameter] ⇒ [Interrupt setting]

## 8.3 In-Error Output Mode Setting

---

This setting allows selection of whether the CPU module clears or holds output to the output module and intelligent function module when a stop error occurs.

### Setting method

Set the output method from "Setting of error-time output mode".

 [Navigation window] ⇒ [Parameter] ⇒ [Module Information] ⇒ Module model name ⇒ [Module Parameter] ⇒ [Setting of error-time output mode]

## 8.4 Output ON Number Count Function

This function counts the number of ON times for each output point of the contact output module within the range of 0 to 4294967295. The count value is held even if the contact output module is powered off.

### Checking the number of ON times

The following two methods are used to read the number of ON times.

- Read it from the buffer memory areas.
- Read it by using the FB that notifies the comparison result of an integration value of the number of relay ON times.

For details on the function block (FB), refer to the following.

 MELSEC iQ-R I/O Module Function Block Reference

### Restriction

When the contact output module is used together with the remote head module, the function block cannot be used.

Check the number of ON times by reading it from the buffer memory areas.

### Buffer memory

The contact output module has buffer memory areas for reading the number of ON times for output.

### Point

Buffer memory areas other than Number of output ON times are system areas. Reading/writing data from/to the system areas may cause malfunction. Writing data to areas of Number of output ON times also may cause malfunction.

○: Can be set

Address (decimal)	Address (hexadecimal)	Name	Default value	Data type	Auto refresh
350, 351	15EH, 15FH	Number of output ON times Y00	0	Monitor	○
352, 353	160H, 161H	Number of output ON times Y01	0	Monitor	○
354, 355	162H, 163H	Number of output ON times Y02	0	Monitor	○
356, 357	164H, 165H	Number of output ON times Y03	0	Monitor	○
358, 359	166H, 167H	Number of output ON times Y04	0	Monitor	○
360, 361	168H, 169H	Number of output ON times Y05	0	Monitor	○
362, 363	16AH, 16BH	Number of output ON times Y06	0	Monitor	○
364, 365	16CH, 16DH	Number of output ON times Y07	0	Monitor	○
366, 367	16EH, 16FH	Number of output ON times Y08 <sup>*1</sup>	0	Monitor <sup>*2</sup>	○ <sup>*2</sup>
368, 369	170H, 171H	Number of output ON times Y09 <sup>*1</sup>	0	Monitor <sup>*2</sup>	○ <sup>*2</sup>
370, 371	172H, 173H	Number of output ON times Y0A <sup>*1</sup>	0	Monitor <sup>*2</sup>	○ <sup>*2</sup>
372, 373	174H, 175H	Number of output ON times Y0B <sup>*1</sup>	0	Monitor <sup>*2</sup>	○ <sup>*2</sup>
374, 375	176H, 177H	Number of output ON times Y0C <sup>*1</sup>	0	Monitor <sup>*2</sup>	○ <sup>*2</sup>
376, 377	178H, 179H	Number of output ON times Y0D <sup>*1</sup>	0	Monitor <sup>*2</sup>	○ <sup>*2</sup>
378, 379	17AH, 17BH	Number of output ON times Y0E <sup>*1</sup>	0	Monitor <sup>*2</sup>	○ <sup>*2</sup>
380, 381	17CH, 17DH	Number of output ON times Y0F <sup>*1</sup>	0	Monitor <sup>*2</sup>	○ <sup>*2</sup>

\*1 System area for the RY18R2A

\*2 "—" for the RY18R2A



# 9 TROUBLESHOOTING

## 9.1 Troubleshooting

### The RUN LED is not on.

Check item	Action
Check whether power is supplied to the power supply module.	Check that the supply voltage to the power supply module is within the rated range.
Check whether the capacity of the power supply module is enough.	Calculate the current consumption of mounted modules, such as the CPU module, I/O modules, and intelligent function modules to check that the power capacity is enough.
Check whether the module is mounted properly.	Check the mounting state of the module.
Cases other than the above	Reset the CPU module and check if the RUN LED turns on. If the RUN LED still remains off, the possible cause is a failure of the module. Please consult your local Mitsubishi representative.

### The I/O status indicator LED is not on.

Check item	Action
Check whether external power supply is supplied to the I/O module.	Check that the supplied power meets the voltage specifications of the I/O module used.
Try forced on on the device concerned by using the engineering tool.	Perform forced on/off on the device concerned to check the correspondence between the device state and the I/O indicator LED. If the error of the I/O indicator LED still persists, the possible cause is a failure of the module. Please consult your local Mitsubishi representative.

# 9.2 Input Circuit Troubles and Corrective Actions

## An input signal does not turn off.

### Case 1

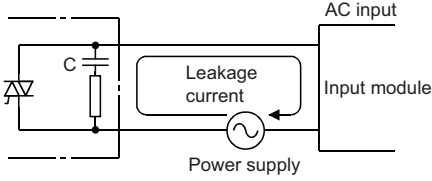
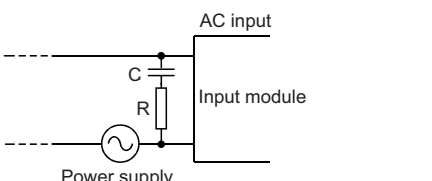
Cause	<p>There is a leakage current from the input switch (driven by a contactless switch and others).</p> 
Action	<p>Connect an appropriate resistor so that the voltage between terminals of the input module would fall below the OFF voltage.</p>  <p>The recommended CR constant is as follows: 0.1 to 0.47<math>\mu</math>F + 47 to 120<math>\Omega</math> (1/2W).</p>

### Case 2

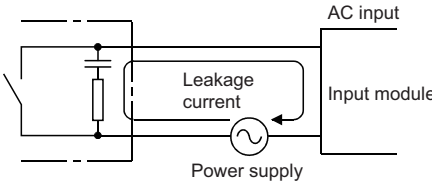
Cause	<p>There is a leakage current from the input switch (driven by a limit switch with neon lamp).</p> 
Action	<p>Take any of the following actions:</p> <ul style="list-style-type: none"> <li>• Connect an appropriate resistor so that the voltage between terminals of the input module would fall below the OFF voltage. (same action as the case 1).</li> <li>• Make the circuit independent and provide another display circuit.</li> </ul>

### Case 3

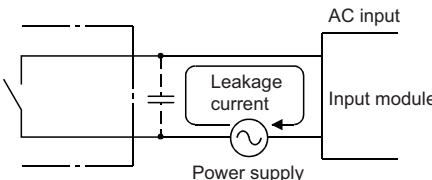
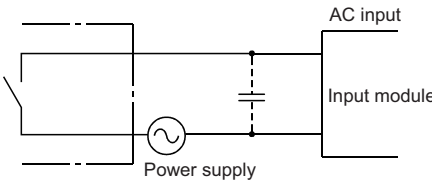
Cause	<p>There is a leakage current due to the line capacity of the wiring cables. (The line capacity, C, of a twisted pair cable is as follows: C = approx. 100pF/m.)</p> 
Action	<p>Connect an appropriate resistor so that the voltage between terminals of the input module would fall below the OFF voltage. (same action as the case 1).</p> <p>A leakage current is not generated, however, where the power supply lies in the input device side like the figure below:</p> 

## Case 4

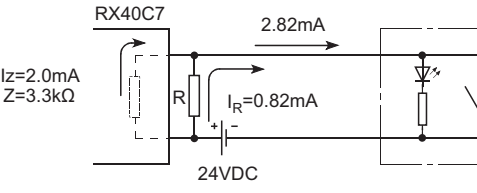
Cause	Even if the switch with LED indicator is turned off, there is a leakage current rising above the OFF current of the input module.
Action	<p>Connect an appropriate resistor so that the current flowing into the input module would fall below the OFF current.</p>  <p>Z: Input impedance</p>
Calculation example	<p>This column gives a calculation example of the resistance value of a resistor to be connected.</p> <p>■ Assuming that a switch with LED indicator where a leakage current of 2.82mA flows by applying a 24VDC power supply is connected to the RX40C7</p> <p>Check the following items referring to the specifications of the module.</p> <ul style="list-style-type: none"> <li>• OFF current: 2.0mA</li> <li>• Input resistance: 3.3kΩ</li> </ul> <p><math>I</math> (Leakage current) = <math>I_Z</math> (OFF current of the RX40C7) + <math>I_R</math> (Current flowing to the connected resistor)</p> <p><math>I_R = I - I_Z = 2.82 - 2.0 = 0.82</math> [mA]</p> <p>To satisfy the condition that an OFF current of the RX40C7 should be lower than 2.0mA, connect a resistor R through which a current of more than 0.82mA will flow. The resistance value, R, of a resistor to be connected is given by the following:</p> <p><math>I_R \cdot I_Z = Z \cdot R</math></p> $R \leq \frac{I_Z}{I_R} \times Z = \frac{2.0}{0.82} \times 3.3 = 8.05 \text{ [k}\Omega\text{]}$ <p>→ The obtained result is: Resistance value <math>R &lt; 8.05\text{k}\Omega</math>.</p> <p>[Checking the connected resistor by calculating power capacity]</p> <p>If the resistance R is 6.8kΩ, the power capacity, W, of the resistance R is given by the following:</p> <ul style="list-style-type: none"> <li>• V: Input voltage</li> </ul> $W = \frac{V^2}{R} = \frac{28.8^2}{6.8 \text{ [k}\Omega\text{]}} = 0.122 \text{ [W]}$ <p>Because the power capacity of a resistor needs to be 3 to 5 times as large as the actual current consumption, a resistor to be connected to the terminal concerned should be 8.2kΩ and 1/2W.</p> <p>In addition, when the resistance R is inserted, the OFF voltage is given by the following:</p> $\frac{1}{\frac{1}{6.8 \text{ [k}\Omega\text{]}} + \frac{1}{3.3 \text{ [k}\Omega\text{]}}} \times 2.82 \text{ [mA]} = 6.27 \text{ [V]}$ <p>This value, therefore, satisfies the condition that an OFF voltage of the RX40C7 should be lower than 8V.</p>

## Case 5

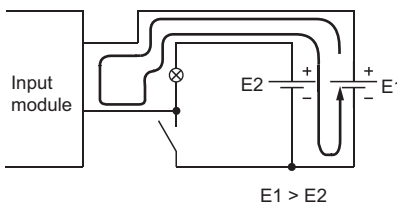
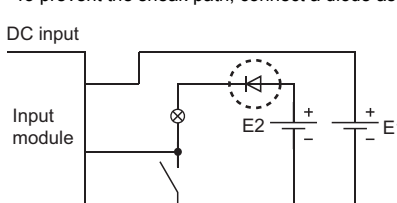
Cause	<p>There is a sneak path allowing current to flow because of the use of two power supplies.</p>  <p><math>E1 &gt; E2</math></p>
Action	<ul style="list-style-type: none"> <li>• Use one power supply.</li> <li>• To prevent the sneak path, connect a diode as shown below:</li> </ul> <p>DC input</p> 

## An input signal does not turn on (AC input module).

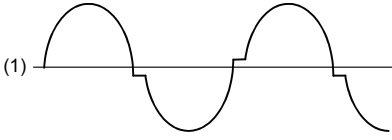
Cause	Around the zero cross voltage (1) of the input signal (AC), there are step-like deformations as shown below: 
Action	Improve the input signal waveform by using an on-line type UPS and others.

## An unintended signal is inputted.

Cause	Noise is taken as input data.
Action	Set the input response time longer. ☞ Page 115 Input Response Time Setting (example) 1ms → 5ms If changing the setting of the input response time has no effect, take the following two measures: <ul style="list-style-type: none"><li>• To prevent excessive noise, avoid installing power cables together with I/O cables.</li><li>• Connect surge absorbers to noise-generating devices such as relays and conductors sharing the same power supply as noise reduction measures.</li></ul>

# 9.3 Output Circuit Troubles and Corrective Actions

## Excessive voltage is applied to the load when the output is off (triac output).

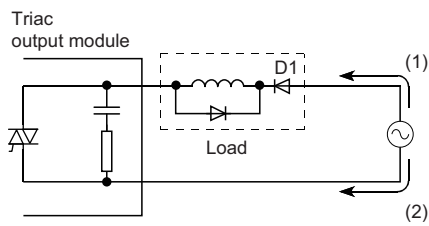
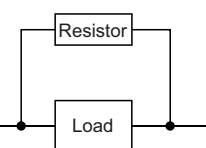
Cause	<p>The load is half-wave rectified internally. (In some cases this is true of solenoids.)</p>  <p>When the polarity of the power supply is as shown in (1), C is charged. When the polarity is as shown in [2], the voltage charged in C plus the line voltage are applied across D1. Maximum voltage is approx. 2.2E. (If a resistor is used in this way, it does not pose a problem to the output element. But it may cause the diode, which is built into the load, to deteriorate, resulting in a fire, etc.)</p>
Action	<p>Connect a resistor (several tens to hundreds of kΩ) across the load.</p> 

## The load does not turn off (triac output).

### ■Case 1

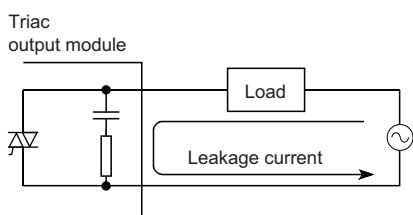
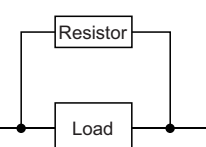
Cause	<p>A leakage current occurred due to a built-in surge suppressor.</p> 
Action	<p>Connect a resistor across the load. (Note that a leakage current may occur due to the line capacity when the wiring distance from the output module to the load is long.)</p> 

## ■ Case 2

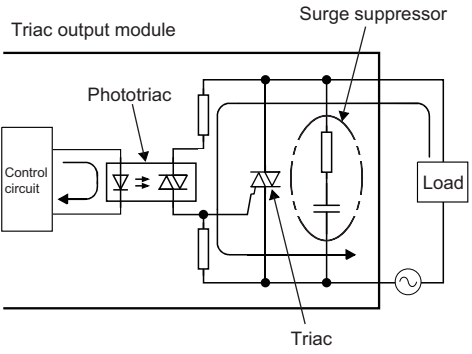
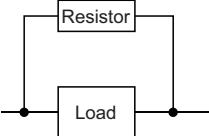
Cause	<p>When the load current is low (lower than 25mA), the triac does not operate and the load current flows to a phototriac as indicated by the arrows in the figure below. If an inductive load is connected as a load in this situation, the load may not turn off because the surge at the time of off is applied to the phototriac.</p> 
Action	<p>Connect a resistor across the load so that the load current of approx. 100mA flows and the triac operation becomes stable. Resistance value <math>\leq</math> Voltage across the load <math>\div</math> 100mA</p>  <p>(Example) When the output voltage is 100VAC, calculate the resistance value by the following formula. <math>100\text{VAC} \div 100\text{mA} = 1\text{k}\Omega</math> Resistance value = <math>1\text{k}\Omega</math></p>

## The load does not turn off (transistor output).

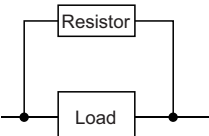
Cause	<p>When a load that operates with a minute current of 0.1mA or lower is connected, the load may not turn off (may turn on) due to a leakage current of the transistor.</p>
Action	<p>Connect a resistor (several tens or hundreds of <math>\text{k}\Omega</math>) across the load.</p> 

## A load momentarily turns on when the external power supply is powered on.

Cause

An incorrect output occurs due to the stray capacitance (C) between collector and emitter of a photocoupler. When a high sensitivity load (such as solid state relay) is used, this incorrect output may occur.

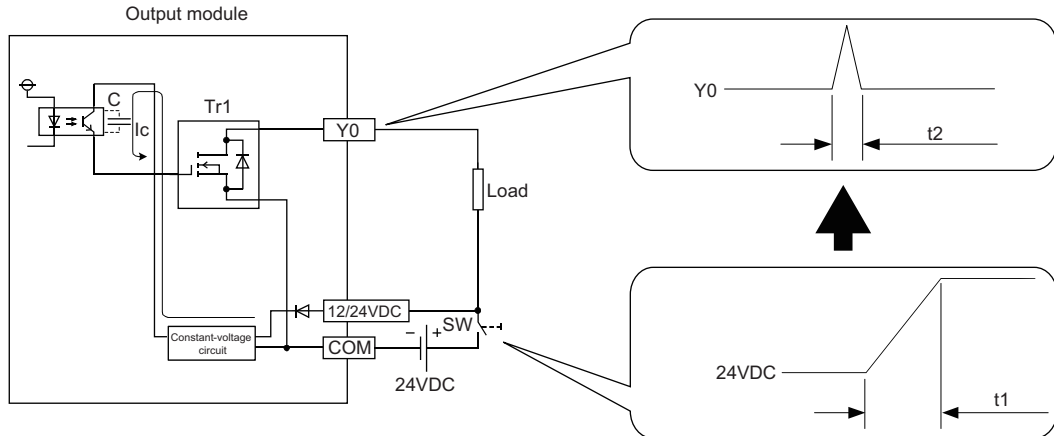

When the voltage rise time is  $t_1$ : less than 10ms at the power-on of the external power supply (24VDC) after the switch-on, the stray capacitance (C) between collector and emitter of the photocoupler allows the current,  $I_c$ , to flow into the gate of the transistor Tr1 on the next stage. As a result, the output Y0 is turned on for about  $t_2$ : 100 $\mu$ s.

Action

Action 1: Before turning on or off the external power supply, check that the rise time of the external power supply is 10ms or more. Then, install a switch (SW1) to the primary side of the external power supply.

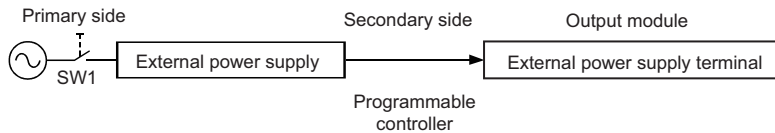

Action 2: If installing the switch to the secondary side is required, connect a capacitor and resistor to slow down the rise time (10ms or more).

However, action 2 is not effective for the following source output modules because of the characteristics of the external power supply circuit, so that take action 1 above.

- RY40PT5P
- RY41PT1P
- RY42PT1P

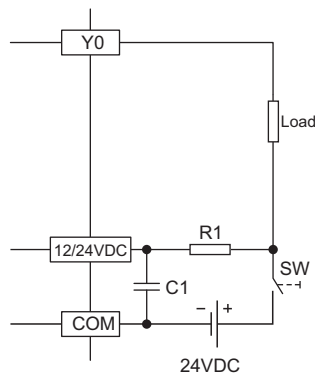

R1: Several tens of ohms

Power capacity  $\geq$  (External power supply current<sup>\*1</sup>)<sup>2</sup>  $\times$  Resistance value  $\times$  (3 to 5)<sup>2</sup>

C1: Several hundreds of microfarads 50V

<Example>

For R1 = 40 $\Omega$  and C1 = 300 $\mu$ F

Time constant = C1  $\times$  R1 = 300  $\times$  10<sup>-6</sup>  $\times$  40 = 12  $\times$  10<sup>-3</sup>[s] = 12ms

\*1 Check the current consumption of the external power supply for modules used.

\*2 Select the power capacity of resistance to be 3 to 5 times as large as the actual power consumption.

## The load in the off state momentarily turns on at power off (transistor output).

Cause

When an inductive load is connected, the load in the off state (2) may turn on due to a sneak current from the back EMF at the shutoff (1).

- Sink output

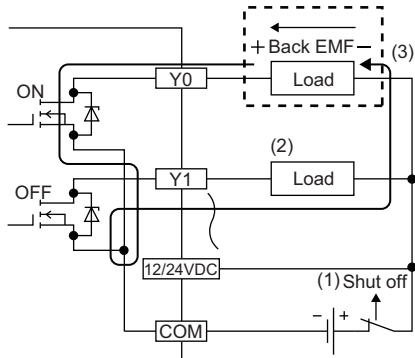

- Source output

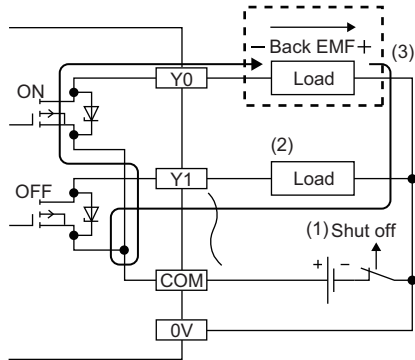

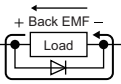
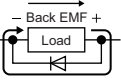
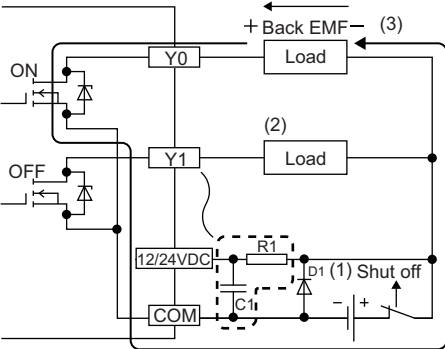

<p>Action</p>	<p>Take either one of the following two actions:</p> <p>Action 1: To suppress the back EMF, connect a diode in parallel with the load under the back EMF influence (3).</p> <ul style="list-style-type: none"> <li>• Sink output</li> </ul>  <ul style="list-style-type: none"> <li>• Source output</li> </ul>  <p>Action 2: Connect a diode into the path between the positive and negative terminals of the external power supply to provide a circulation path. When simultaneously performing the action described earlier under "A load momentarily turns on when the external power supply is powered on.", connect the diode in parallel with C1 and R1 (as shown in the dot frame of the figure below).  <small>☞ Page 125 A load momentarily turns on when the external power supply is powered on.</small></p> <p>However, action 2 is not effective for the following source output modules because of the characteristics of the external power supply circuit, so that take action 1 above.</p> <ul style="list-style-type: none"> <li>• RY40PT5P</li> <li>• RY41PT1P</li> <li>• RY42PT1P</li> </ul>  <p>D1 is in the following state.</p> <ul style="list-style-type: none"> <li>• Reverse voltage VR (VRM): Approximately 10 times as high as the rated voltage in the specifications</li> </ul> <p>&lt;Example&gt;      24VDC → Approximately 200V</p> <ul style="list-style-type: none"> <li>• Forward current IF (IFM): More than twice as much as the maximum load current (common) in the specifications</li> </ul> <p>&lt;Example&gt;      2A/1 common → 4A or more</p>
---------------	--

**A load operates only by turning on the external power supply (transistor output).**

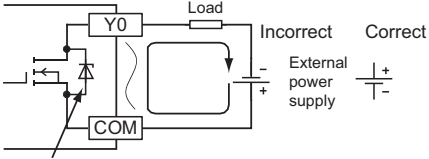
<p>Cause</p>	<ul style="list-style-type: none"> <li>• The external power supply is connected with its polarity reversed.</li> </ul>  <p>Output element protection diode</p> <ul style="list-style-type: none"> <li>• The reversed polarity may allow current to flow via the output element protection diode into the load.</li> </ul>
<p>Action</p>	<p>Connect the external power supply with the correct polarity.</p>

## A load inputs data incorrectly due to a chattering.

Cause	A device with a high input response speed is connected to the contact output module.
Action	Use a transistor output module.

## At output On, even loads in connection to other output simultaneously turn on.

The following fault example and its corrective action are for the transistor output (source type).

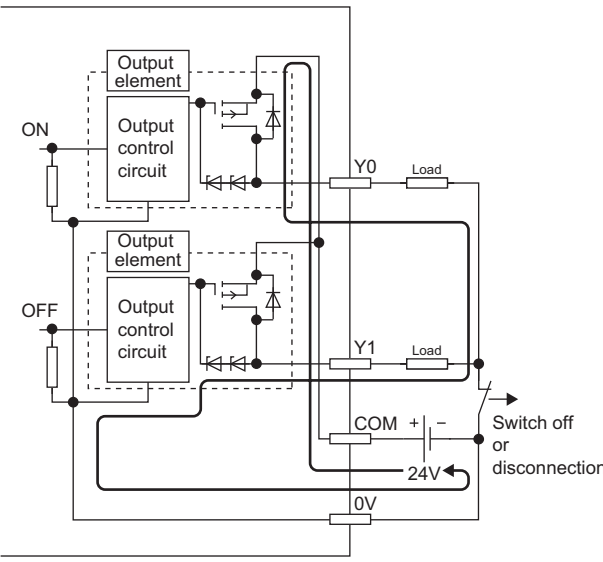
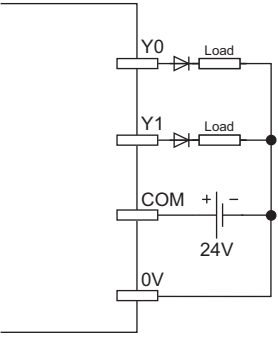
Cause	<p>A non-connection state between the external power supply 0V and the common line of the load due to interruption or disconnection causes a current to flow to the load in off state through the parasitic circuit connected to the output element in off state.</p> 
	<p>Continuous use in this condition may cause a failure.</p>
Action	<p>Correctly connect the external power supply and the load. To prevent further occurrence of the situation above, insert diodes to each output terminal as shown below:</p> 

# APPENDICES

## Appendix 1 Optional Items

### Connector/terminal block converter modules

Model	Description	Weight	Applicable wire size	Applicable solderless terminal
A6TBXY36	For positive common type input module For sink/source type output module (standard type)	0.4kg	0.75 to 2mm <sup>2</sup>	1.25-3.5 (JIS) 1.25-YS3A V1.25-M3 V1.25-YS3A 2-3.5 (JIS) 2-YS3A V2-S3 V2-YS3A
A6TBXY54	For positive common type input module For sink/source type output module (2-wire type)	0.5kg		
A6TBX70	For positive common type input module (3-wire type)	0.6kg		

### Included products

Product	Description	Quantity
M4×25 screw	A screw for mounting the connector/terminal block converter module onto a panel	2

### Availability of the connector/terminal block converter module

Product	Model	A6TBXY36	A6TBXY54	A6TBX70
Input module <sup>*1</sup>	RX41C4	○	○	○
	RX42C4	○	○	○
	RX41C6HS	○	○	○
	RX61C6HS	○	○	○
	RX71C4	○	○	○
	RX72C4	○	○	○
Output module	RY41NT2P	○	○	×
	RY41NT2H	○	○	×
	RY42NT2P	○	○	×
	RY41PT1P	○	○	×
	RY41PT2H	○	○	×
	RY42PT1P	○	○	×
I/O combined module	RH42C4NT2 P	Input side <sup>*1</sup>	○	○
		Output side	○	○

\*1 Available only when using a positive common.

#### Point

- The number of connectable I/O points is 32 for all the connector/terminal block converter modules. An I/O module with 64 points requires two sets of the connector/terminal block converter module and its cable.
- The terminal screws (M3.5) of the module require a tightening torque of 0.78N·m.

A

## Part names

A6TBXY36

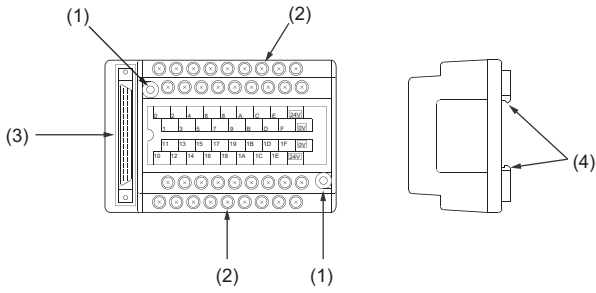

A6TBXY54

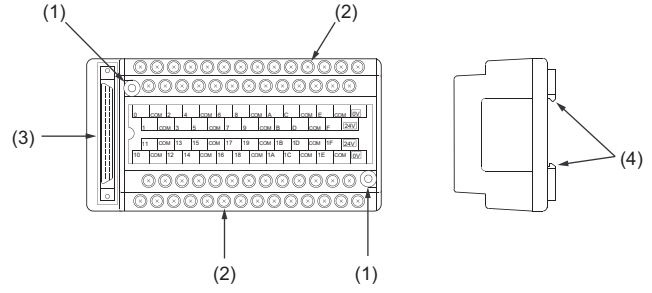

A6TBX70

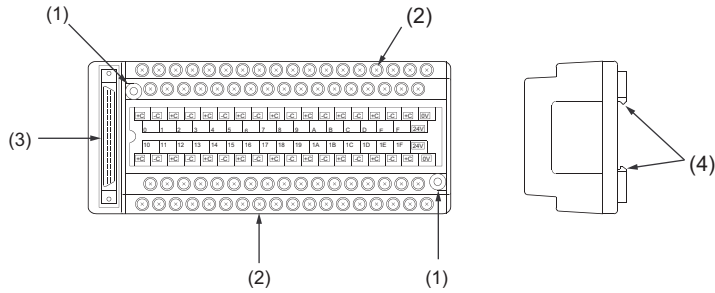

No.	Name	Description
(1)	Panel mounting hole	A hole for mounting the module onto a panel with the screw (M4 screw, included product)
(2)	Terminal block	A terminal block for connecting a power supply and I/O signal wire
(3)	40-pin connector	A connector for connecting the AC□□TB  Page 135 Connector-equipped dedicated cables
(4)	Module fixing hook	A hook for mounting the module onto a DIN rail

## Connection diagram

### ■A6TBXY36

- When connecting an input module

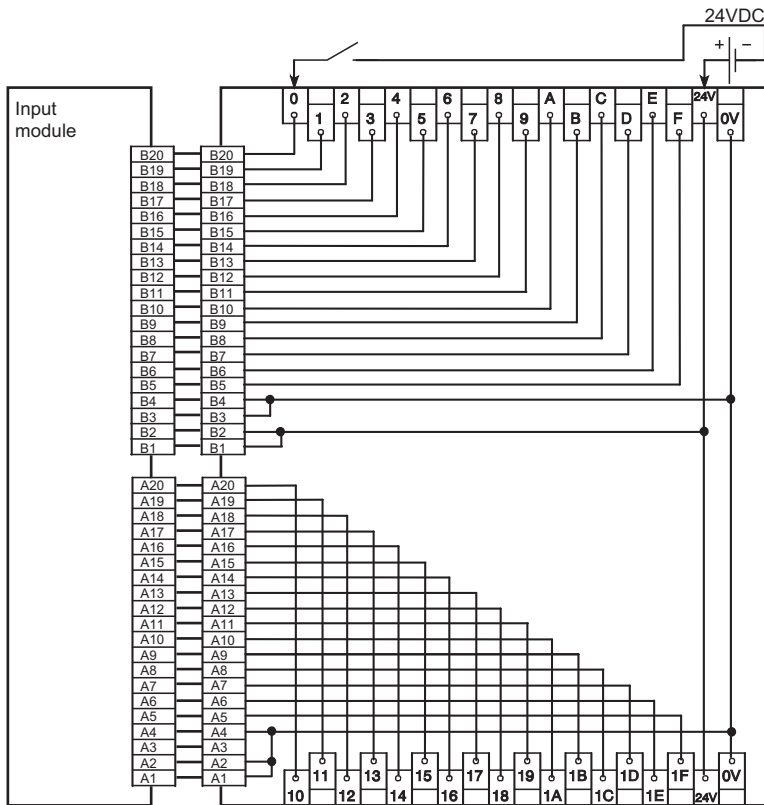

- When connecting an output module (sink type)

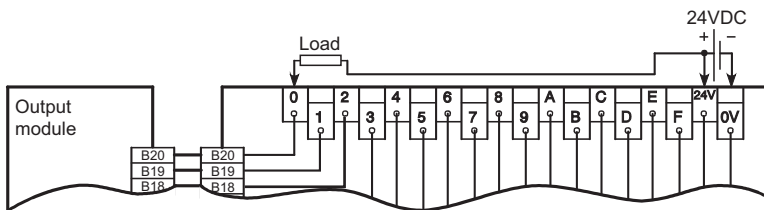

- When connecting an output module (source type)

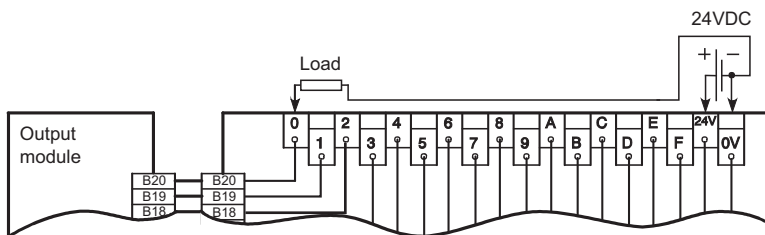

A

## ■A6TBXY54

- When connecting an input module

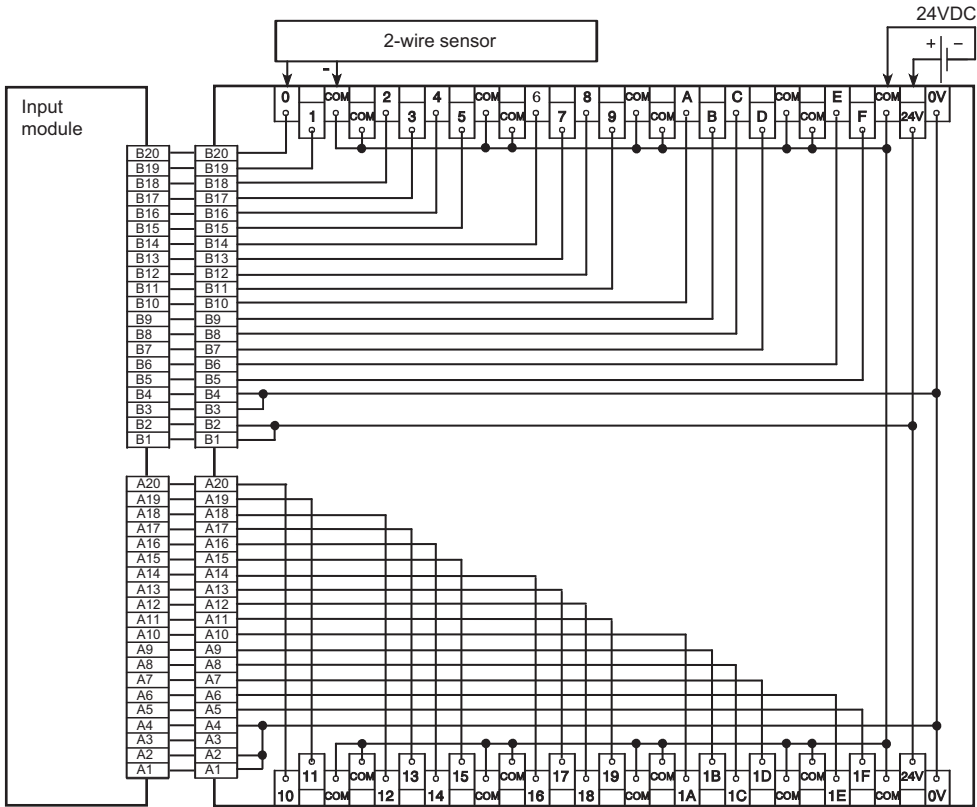

- When connecting an output module (sink type)

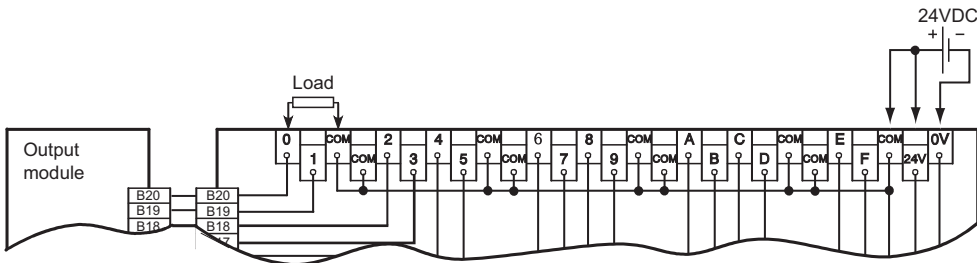

- When connecting an output module (source type)

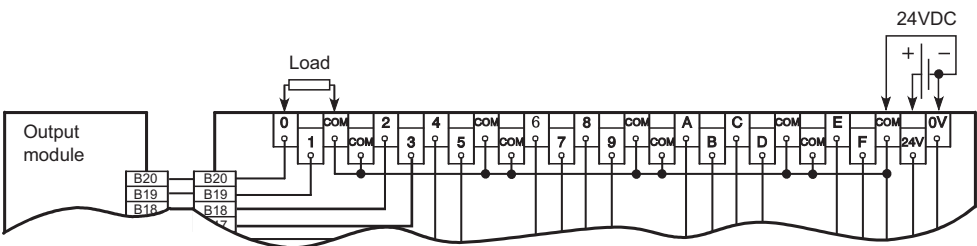

■A6TBX70

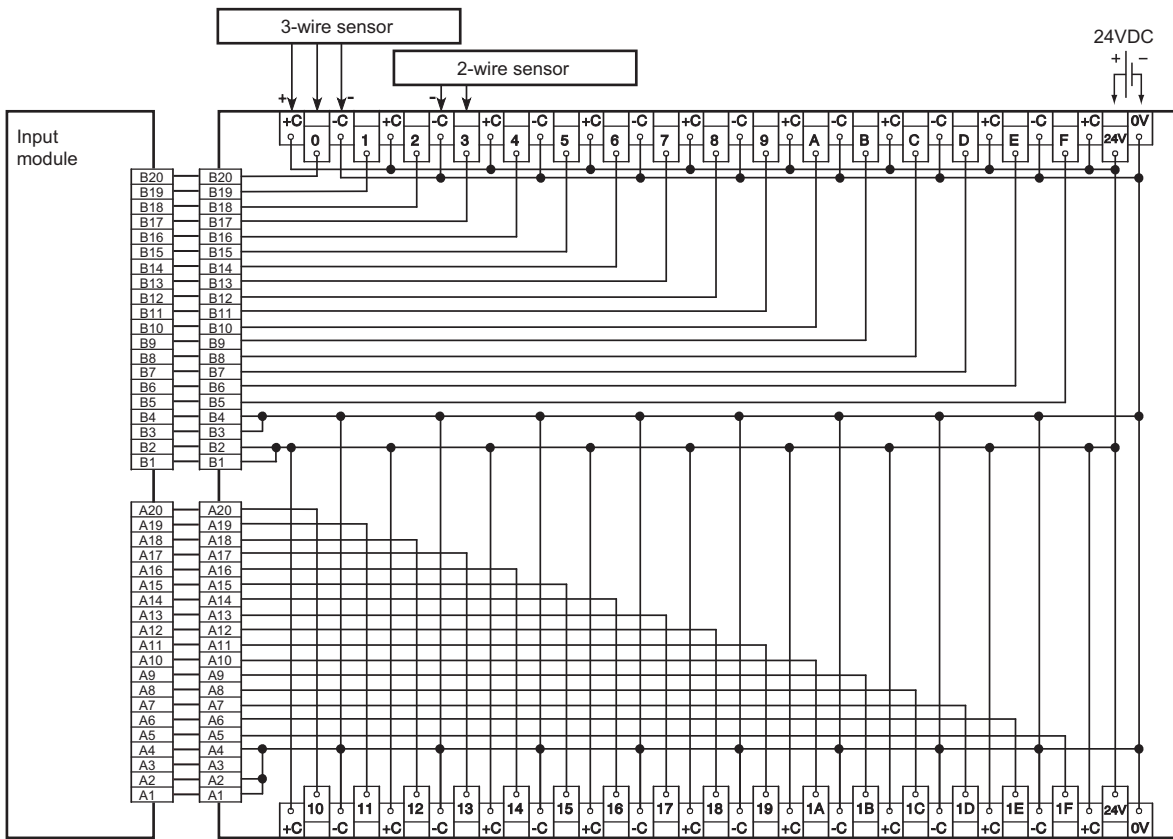

## Relay terminal module (A6TE2-16SRN)

The A6TE2-16SRN serves as a substitute for the relay terminal blocks and relays in a control panel, which reduces the man-hours for wiring among the programmable controllers, relay terminal blocks, and relays. This module can be used only with the sink type output module (40-pin connector).

For details on the relay terminal module and dedicated cable with connector, refer to the following.

📖 Relay Terminal Module User's Manual (Hardware) A6TE2-16SRN

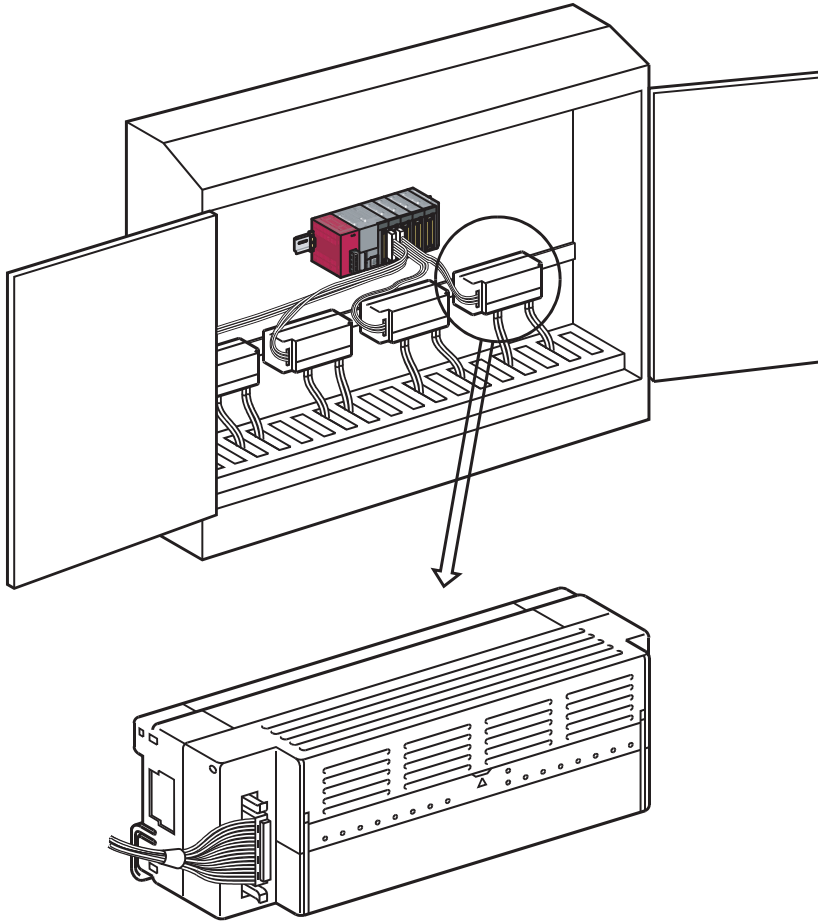

A6TE2-16SRN

Item		Specifications
Number of output points		16 points
Isolation method		Relay
Rated switching voltage/current		24VDC 2A (resistive load)/point, 8A/common 240VAC 2A (COS $\phi$ = 1)/point
Response time	OFF→ON	10ms or less
	ON→OFF	12ms or less
Surge suppressor		None
Fuse		None
Wiring method for common		8 points/common



## Connector-equipped dedicated cables

### For connector/terminal block converter module

Model	Description	Weight	Applicable module
AC05TB	0.5m, for sink/source type module	0.17kg	A6TBXY36 A6TBXY54 A6TBX70
AC10TB	1m, for sink/source type module	0.23kg	
AC20TB	2m, for sink/source type module	0.37kg	
AC30TB	3m, for sink/source type module	0.51kg	
AC50TB	5m, for sink/source type module	0.76kg	
AC80TB <sup>*1</sup>	8m, for sink/source type module	1.2kg	
AC100TB <sup>*1</sup>	10m, for sink/source type module	1.5kg	

\*1 The cable length is so long that the voltage drop would be higher. When using the AC80TB and AC100TB, the common current should be 0.5A or lower.

### For relay terminal module

Model	Description	Applicable module
AC06TE	0.6m, for sink type module	A6TE2-16SRN
AC10TE	1m, for sink type module	
AC30TE	3m, for sink type module	
AC50TE	5m, for sink type module	
AC100TE	10m, for sink type module	

## Spring clamp terminal block

The spring clamp terminal block Q6TE-18SN for the Q series can be mounted for use.

For details on the Q6TE-18SN, refer to the following.

 Before Using the Product (BCN-P5999-0209)

## Converter module and interface module (FA goods)

Converter modules and interface modules (manufactured by Mitsubishi Electric Engineering Co., Ltd.) are available.

For details, please consult your local Mitsubishi representative.

# Appendix 2 Compatibility of MELSEC iQ-R series I/O Modules with MELSEC Q/L Series I/O Modules

This section describes the compatibility of MELSEC iQ-R series I/O modules with MELSEC Q/L series I/O modules.

## 18-point screw terminal block type module

Item	Compatibility with the Q series	Compatibility with the L series
Terminal block	Compatible and available. The terminal layout is the same as that of the Q series.	Not compatible and not available. The shape of the terminal block is different from the L series.

## 40-pin connector type module

Item	Compatibility with the Q series	Compatibility with the L series
Connector	Compatible and available. The pin layout is the same as that of the Q series.	Compatible and available. The pin layout is the same as that of the L series.

# Appendix 3 External Dimensions

## I/O module, blank cover module

### 18-point screw terminal block type module

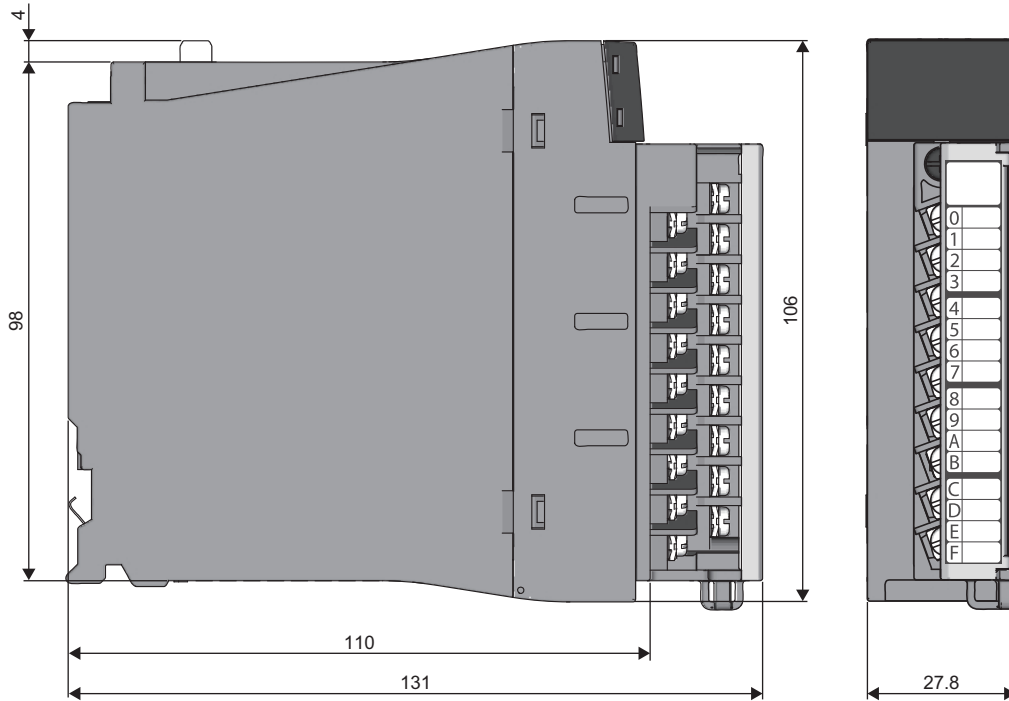

(Unit: mm)

A

## 40-pin connector type module

### ■32 points module

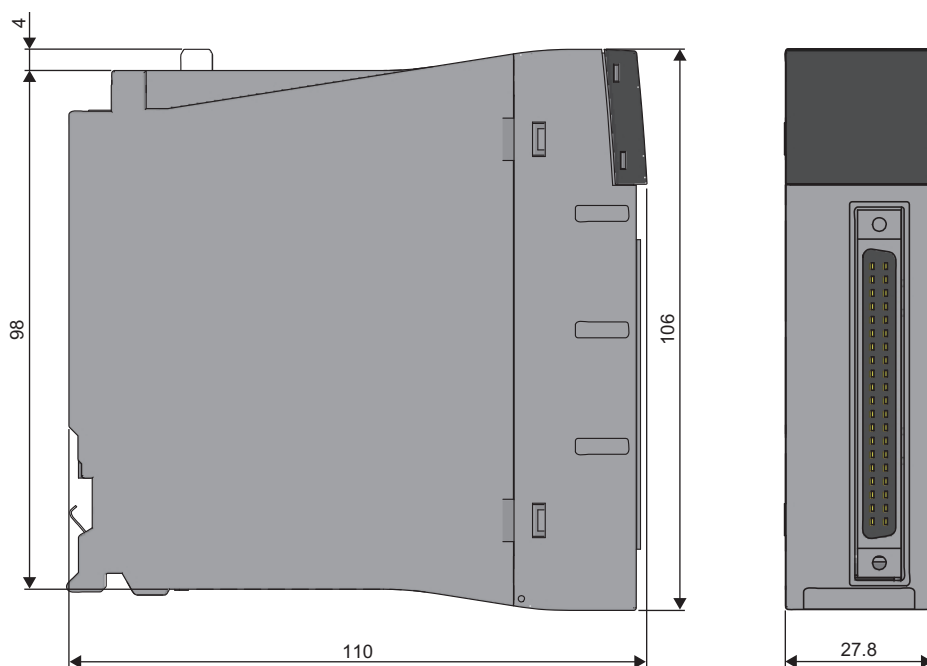

(Unit: mm)

### ■64 points module

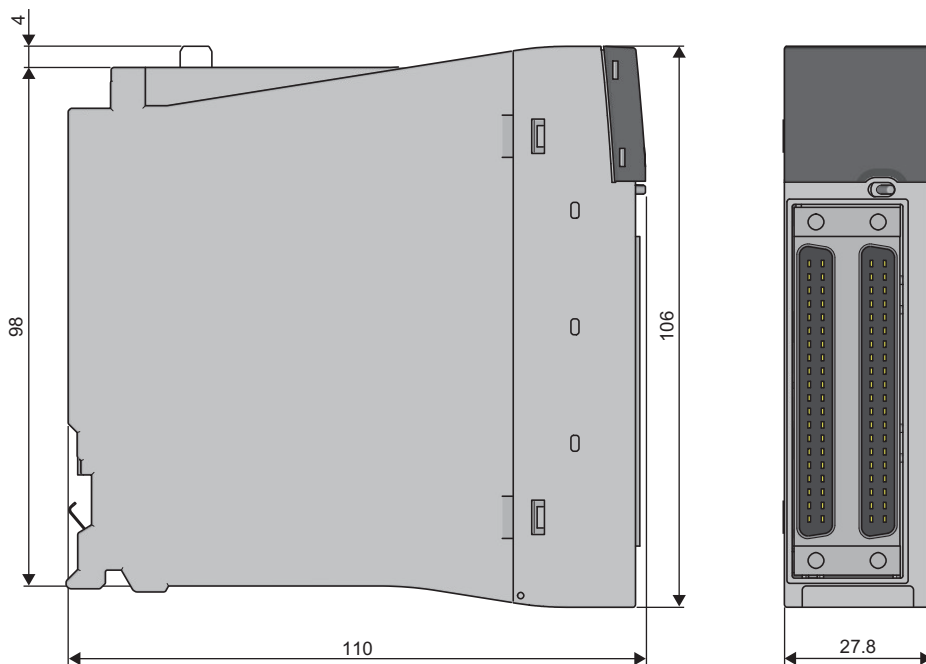

(Unit: mm)

## Spring clamp terminal block type module

### ■16 points module

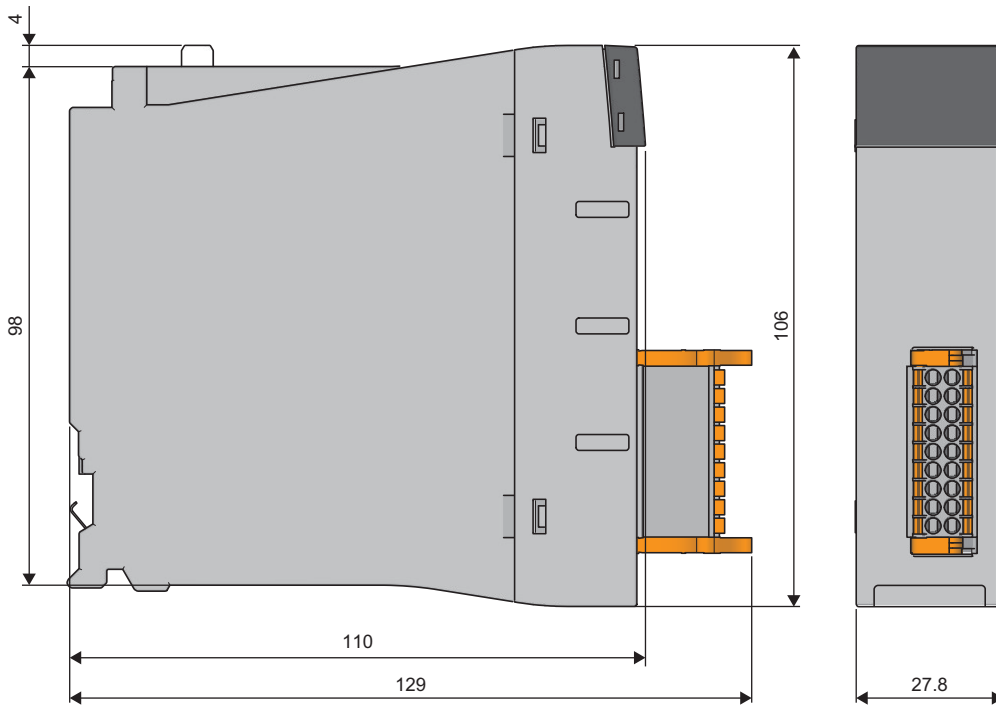

(Unit: mm)

### ■32 points module

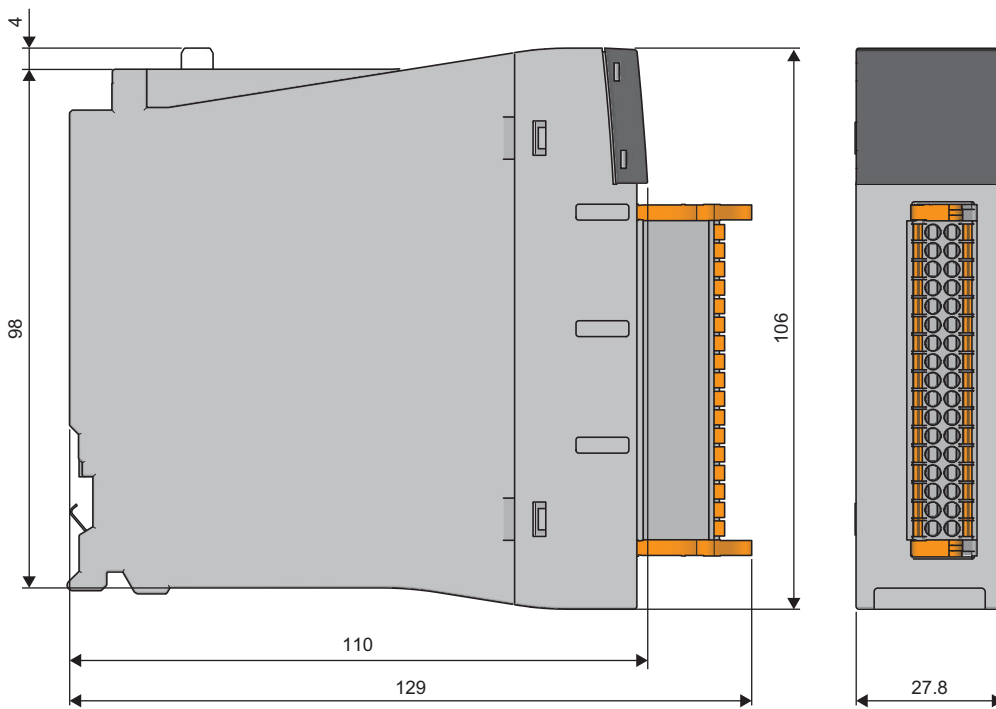

(Unit: mm)

A

## Blank cover module

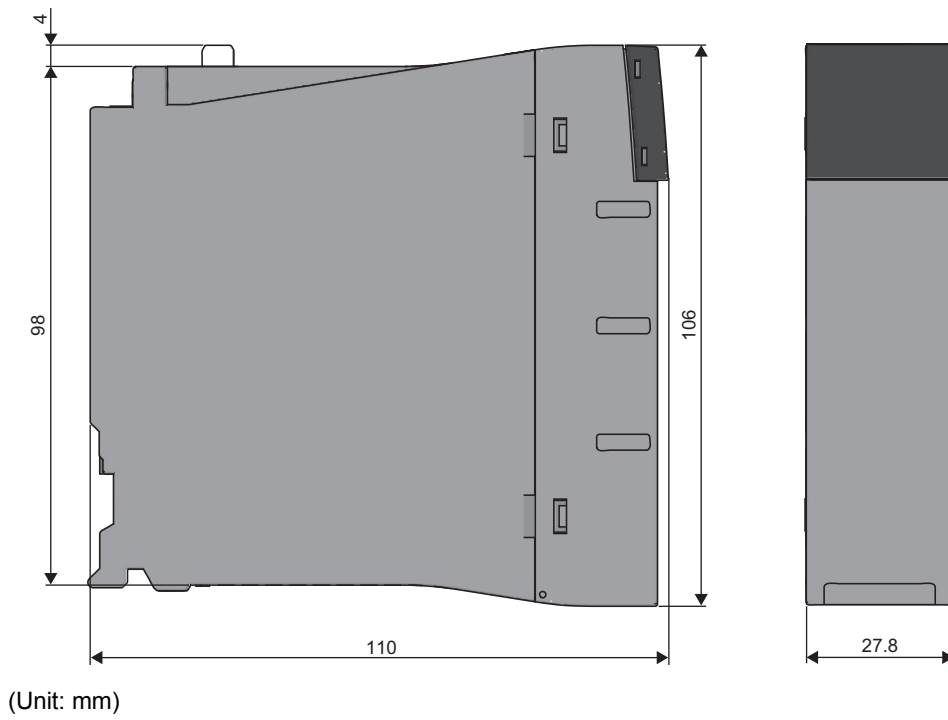

# Connectors

- A6CON1 (soldering type 40-pin connector), A6CON2 (crimping type 40-pin connector)

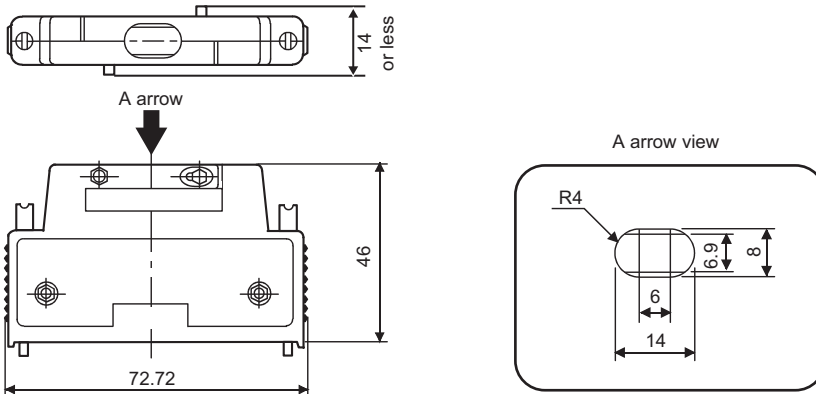

(Unit: mm)

- A6CON3 (IDC type 40-pin connector)

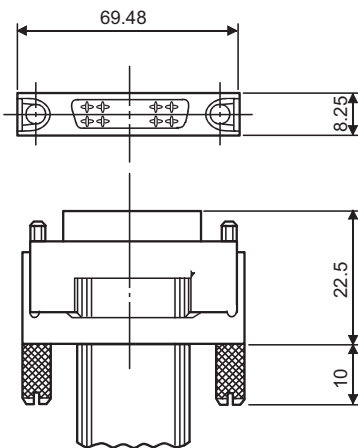

(Unit: mm)

- A6CON4 (soldering type 40-pin connector)

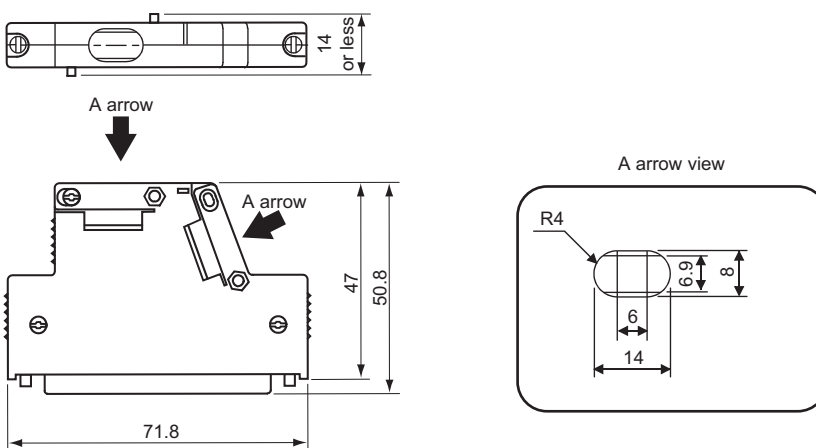

(Unit: mm)

A smaller cable diameter than the clamp part may cause the cable to come off the clamp part.

Wrap the cable with tape and others to fix it before use.

For the cable made of a slippery material, wrap it with rubber tape and others as an anti-slip measure.



# Connector/terminal block converter modules

• A6TBXY36

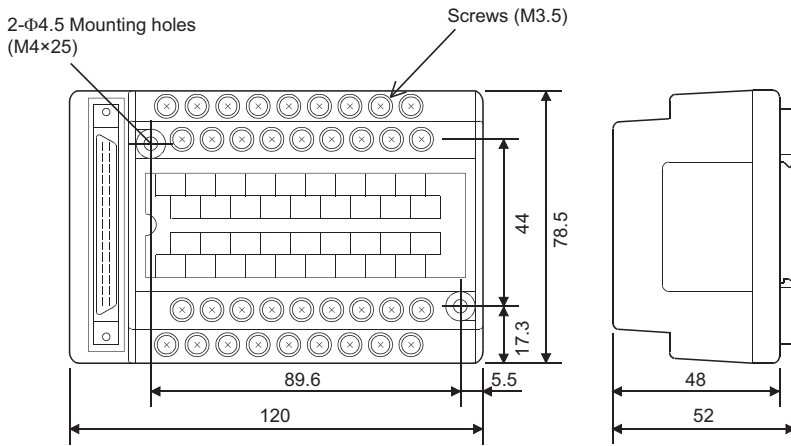

(Unit: mm)

• A6TBX54

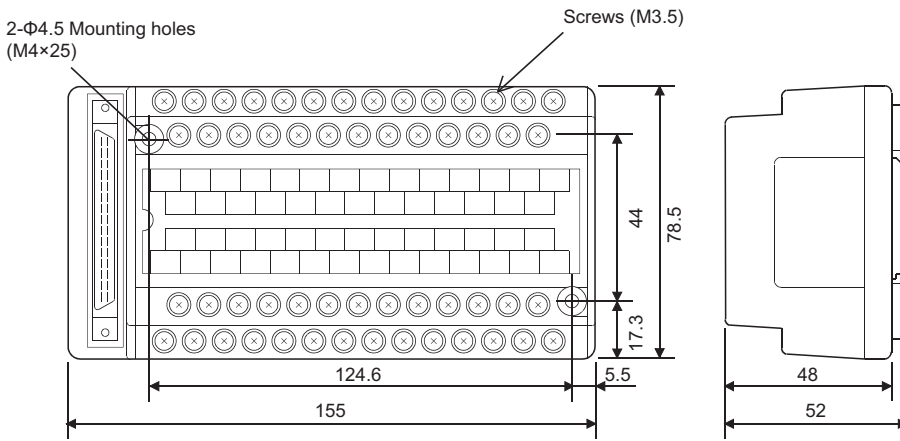

(Unit: mm)

• A6TBX70

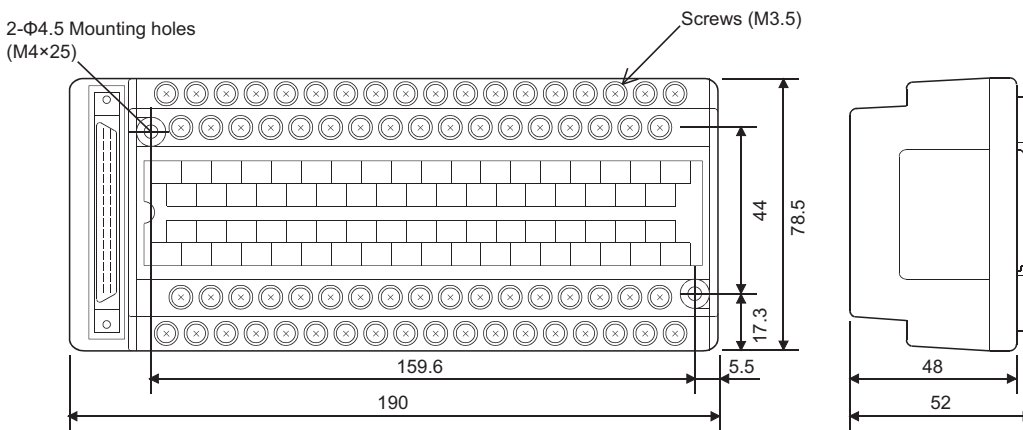

(Unit: mm)



## Cable for connector/terminal block converter module

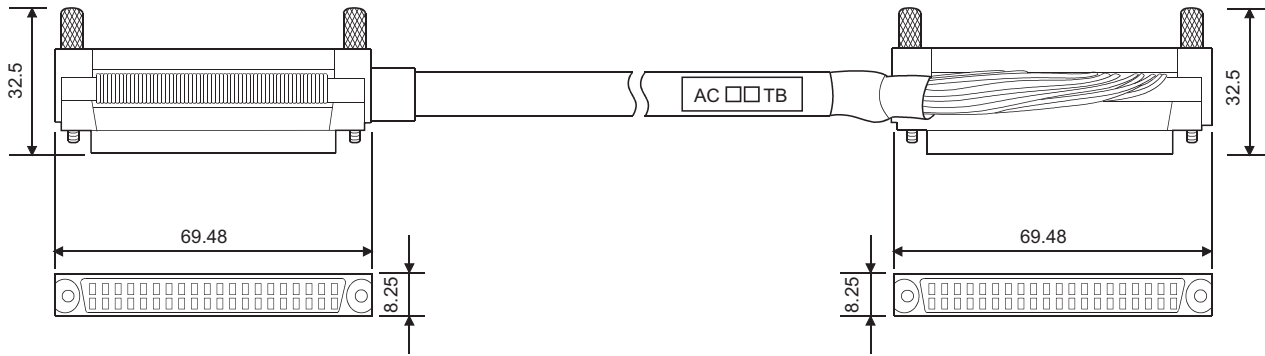

(Unit: mm)

# INDEX

---

## I

---

I/O status indicator LED . . . . .	19
Indication selector switch . . . . .	19
In-error output mode setting . . . . .	117
Input response time setting . . . . .	111,115
Inter-module synchronization function . . . . .	88
Interrupt input function . . . . .	116
Interrupt setting . . . . .	112

## O

---

Output ON number count function . . . . .	118
Overheat protection . . . . .	51,84
Overload protection . . . . .	51,84

## R

---

Refresh setting . . . . .	114
RG60 blank cover module . . . . .	87
RH42C4NT2P DC input/transistor output combined module . . . . .	85
RUN LED . . . . .	19
RX10 AC input module . . . . .	21,23
RX28 AC input module . . . . .	25
RX40C7 DC input module . . . . .	27,29,37,39,41
RX40NC6H DC high-speed input module . . . . .	45
RX40PC6H DC high-speed input module . . . . .	43
RX41C4 DC input module . . . . .	31,33
RX41C6HS DC high-speed input module . . . . .	47
RX42C4 DC input module . . . . .	35
RX61C6HS DC high-speed input module . . . . .	49
RY10R2 contact output module . . . . .	52,54
RY18R2A contact output module (all points independent contact) . . . . .	56
RY20S6 triac output module . . . . .	58
RY40NT5P transistor output module . . . . .	60,62
RY40PT5P transistor output module . . . . .	72,74
RY41NT2H transistor high-speed output module . . . . .	68
RY41NT2P transistor output module . . . . .	64,66
RY41PT1P transistor output module . . . . .	76,78
RY41PT2H transistor high-speed output module . . . . .	80
RY42NT2P transistor output module . . . . .	70
RY42PT1P transistor output module . . . . .	82

## S

---

Setting of error-time output mode . . . . .	113
---	-----

# MEMO

---

# REVISIONS

\*The manual number is given on the bottom left of the back cover.

Revision date	*Manual number	Description
June 2014	SH(NA)-081247ENG-A	First edition
April 2015	SH(NA)-081247ENG-B	<ul style="list-style-type: none"> <li>■ Added models RX40PC6H, RX40NC6H</li> <li>■ Added function Online module change</li> <li>■ Added or modified parts Section 7.1, 8.1</li> </ul>
January 2016	SH(NA)-081247ENG-C	<ul style="list-style-type: none"> <li>■ Added models RY41NT2H, RY41PT2H</li> </ul>
May 2016	SH(NA)-081247ENG-D	<ul style="list-style-type: none"> <li>■ Added models RX41C6HS, RX61C6HS</li> <li>■ Added or modified parts SAFETY PRECAUTIONS, Section 1.2, Chapter 2, Section 3.1, 5.1, 6.1, 6.3, 8.4, 9.2, 9.3, Appendix 1, 3</li> </ul>
October 2016	SH(NA)-081247ENG-E	<ul style="list-style-type: none"> <li>■ Added models RY20S6</li> <li>■ Added or modified parts Section 1.1, 1.2, Chapter 2, Section 3.1, 6.1, 6.2, 7.1, 9.3</li> </ul>
February 2017	SH(NA)-081247ENG-F	<ul style="list-style-type: none"> <li>■ Added models RX28, RY18R2A</li> <li>■ Added or modified parts Section 1.1, 1.2, 3.1, 6.1, 9.3</li> </ul>
April 2018	SH(NA)-081247ENG-G	<ul style="list-style-type: none"> <li>■ Added models RX10-TS, RX40C7-TS, RX41C4-TS, RX70C4, RX71C4, RX72C4, RY10R2-TS, RY40NT5P-TS, RY41NT2P-TS, RY40PT5P-TS, RY41PT1P-TS</li> <li>■ Added or modified parts Chapter 1, 2, Section 3.1, 6.1, 6.2, Appendix 1, 3</li> </ul>
November 2019	SH(NA)-081247ENG-H	<ul style="list-style-type: none"> <li>■ Added or modified parts Section 3.1, 9.3</li> </ul>

Japanese manual number: SH-081246-H

This manual confers no industrial property rights of any other kind, nor does it confer any patent licenses. Mitsubishi Electric Corporation cannot be held responsible for any problems involving industrial property rights which may occur as a result of using the contents noted in this manual.

© 2014 MITSUBISHI ELECTRIC CORPORATION

# WARRANTY

---

Please confirm the following product warranty details before using this product.

## **1. Gratis Warranty Term and Gratis Warranty Range**

If any faults or defects (hereinafter "Failure") found to be the responsibility of Mitsubishi occurs during use of the product within the gratis warranty term, the product shall be repaired at no cost via the sales representative or Mitsubishi Service Company.

However, if repairs are required onsite at domestic or overseas location, expenses to send an engineer will be solely at the customer's discretion. Mitsubishi shall not be held responsible for any re-commissioning, maintenance, or testing on-site that involves replacement of the failed module.

[Gratis Warranty Term]

The gratis warranty term of the product shall be for one year after the date of purchase or delivery to a designated place. Note that after manufacture and shipment from Mitsubishi, the maximum distribution period shall be six (6) months, and the longest gratis warranty term after manufacturing shall be eighteen (18) months. The gratis warranty term of repair parts shall not exceed the gratis warranty term before repairs.

[Gratis Warranty Range]

- (1) The range shall be limited to normal use within the usage state, usage methods and usage environment, etc., which follow the conditions and precautions, etc., given in the instruction manual, user's manual and caution labels on the product.
- (2) Even within the gratis warranty term, repairs shall be charged for in the following cases.
  1. Failure occurring from inappropriate storage or handling, carelessness or negligence by the user. Failure caused by the user's hardware or software design.
  2. Failure caused by unapproved modifications, etc., to the product by the user.
  3. When the Mitsubishi product is assembled into a user's device, Failure that could have been avoided if functions or structures, judged as necessary in the legal safety measures the user's device is subject to or as necessary by industry standards, had been provided.
  4. Failure that could have been avoided if consumable parts (battery, backlight, fuse, etc.) designated in the instruction manual had been correctly serviced or replaced.
  5. Failure caused by external irresistible forces such as fires or abnormal voltages, and Failure caused by force majeure such as earthquakes, lightning, wind and water damage.
  6. Failure caused by reasons unpredictable by scientific technology standards at time of shipment from Mitsubishi.
  7. Any other failure found not to be the responsibility of Mitsubishi or that admitted not to be so by the user.

## **2. Onerous repair term after discontinuation of production**

- (1) Mitsubishi shall accept onerous product repairs for seven (7) years after production of the product is discontinued. Discontinuation of production shall be notified with Mitsubishi Technical Bulletins, etc.
- (2) Product supply (including repair parts) is not available after production is discontinued.

## **3. Overseas service**

Overseas, repairs shall be accepted by Mitsubishi's local overseas FA Center. Note that the repair conditions at each FA Center may differ.

## **4. Exclusion of loss in opportunity and secondary loss from warranty liability**

Regardless of the gratis warranty term, Mitsubishi shall not be liable for compensation to:

- (1) Damages caused by any cause found not to be the responsibility of Mitsubishi.
- (2) Loss in opportunity, lost profits incurred to the user by Failures of Mitsubishi products.
- (3) Special damages and secondary damages whether foreseeable or not, compensation for accidents, and compensation for damages to products other than Mitsubishi products.
- (4) Replacement by the user, maintenance of on-site equipment, start-up test run and other tasks.

## **5. Changes in product specifications**

The specifications given in the catalogs, manuals or technical documents are subject to change without prior notice.

# TRADEMARKS

---

The company names, system names and product names mentioned in this manual are either registered trademarks or trademarks of their respective companies. In some cases, trademark symbols such as '™' or '®' are not specified in this manual.



SH(NA)-081247ENG-H(1911)MEE

MODEL: R-IO-U-E

MODEL CODE: 13JX07

## **mitsubishi electric corporation**

HEAD OFFICE : TOKYO BUILDING, 2-7-3 MARUNOUCHI, CHIYODA-KU, TOKYO 100-8310, JAPAN  
NAGOYA WORKS : 1-14, YADA-MINAMI 5-CHOME, HIGASHI-KU, NAGOYA, JAPAN

When exported from Japan, this manual does not require application to the  
Ministry of Economy, Trade and Industry for service transaction permission.

Specifications subject to change without notice.